

# *Batteries and Fuel Cells*

John C. Bean

## Outline

Battery History / Battery Science

Batteries in TODAY's homes & ground vehicles

Your car's starting battery: Lead Acid

Your home's economy disposable battery: Zinc-Carbon (actually Zn / MnO<sub>2</sub>)

Your home's premium disposable battery: Zn-MnO<sub>2</sub> based Alkaline

Your home's older rechargeable battery: Ni-Cd based Alkaline

Your home's newer rechargeable battery: Nickel Metal Hydride based Alkaline

Your home's, car's, tool's, solar array's . . . newest reusable battery: Something based on Lithium

Batteries in TOMORROW's homes & ground vehicles

Including future Li-Ion batteries, Aqueous Hybrid Ion / Saltwater, and Lithium Air batteries

Why practical battery-powered air & sea transport are a long way off

Airplanes's need for power produced from very little mass - for which fossil-fuels are hugely better

Ships's need for vast amounts of stored energy

Batteries in TOMORROW's greener electrical Grid

Which may be key to the large-scale integration of solar and wind power

But which requires HUGE amounts of stored energy (whatever the volume & mass!)

Leading to weird new batteries including: Flow, Molten Sodium, and entirely Molten batteries

Fuel Cells: Closely related to batteries, but with important differences

*(Written / Revised: July 2023)*

## A Battery Glossary:

Suggested by definitions given in "What are Batteries, Fuel Cells and Supercapacitors?" <sup>1</sup>

**Cell:** Basic building block, typically one anode and one cathode, between which is an ion-conducting electrolyte (and possible separator).

**Battery:** One or more electrically connected cells, plus terminals/contacts to pass electrical energy to outside world.

**Primary Battery:** Fully charged as built (based on its constituents). Discharged once and then discarded.

**Secondary Battery:** Usually discharged as built. Charged, and subsequently rechargeable, by application of an external voltage (as possibly supplied by a Primary Battery).

**Anode:** Negative electrode of a cell, associated with "oxidative" chemical reactions that **release electrons** into the external circuit.

**Cathode:** Positive electrode of a cell, associated with "reductive" chemical reactions that **gain electrons** from the external circuit.

**Electrolyte:** Material that **provides pure ionic conductivity** between the positive and negative electrodes of a battery cell.

**Separator:** An inert physical barrier between the electrodes of some cells. Added to **inhibit electrical shorts and/or mixing of two electrolytes, while maintaining the flow of key ions.**

*Many of my teachers were fascinated with batteries*

Elementary school teachers had us wire together slivers of metal stuck into lemons

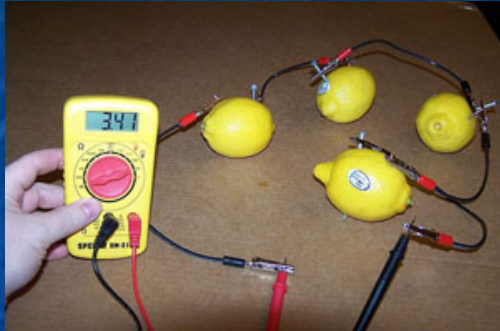

Which WERE a lot of fun to mess around with

***But they looked like no battery I'd ever seen!***

High school Chemistry teachers then went on and on (and on) about how metals

dissolved into water as ions (and the converse),

which they breathlessly labeled "**Redox reactions**"

Our textbooks said this enabled batteries looking like this:

***Which ALSO looked like no battery I'd ever seen!***

**AND** which had unexplained features (e.g., glass "salt bridges")

that seemed both bizarre and hopelessly impractical

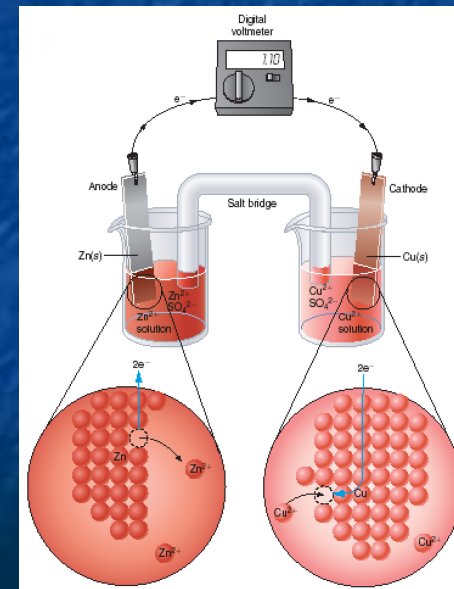

Top figure (and excellent tutorial): [http://www.edinformatics.com/math\\_science/how\\_does\\_a\\_battery\\_work.htm](http://www.edinformatics.com/math_science/how_does_a_battery_work.htm)

Bottom figure: <http://courses.washington.edu/bhchem/c456/ch11.pdf>

*And batteries didn't have a big impact on my day-to-day life*

Yes, they powered an occasional portable radio or toy

And, if I'd stopped to think about it, they kick-started the family cars

But their major function seemed to be powering household flashlights,

something they could do for only a **frustratingly short period of time**

And when I left school and joined the Research Division of Bell Telephone Labs,

(then the biggest and most productive industrial research lab in the world)

I was given a free choice of my own research direction

But mentors (including Chemists) counseled me against battery research

because they considered it not only slow moving (if not stagnant)

but also of limited relevance to real world or Bell System problems

*All of which effectively curtailed my interest in, and study of, batteries*

*But in the 1990's batteries were back in the news (and the news was bad)*

During the 1980's we'd become addicted to **desktop** personal computers

In the 1990's we decided what we *really* needed were **portable** personal computers

Early models of which were fragile beasts weighing 10-15 pounds,

that were limited by either their battery's 1-2 hour lifetime

or by our shoulder's refusal to lug around that hulking battery

The millennium added similar addictions to PDA's, and then to mobile phones

Thus by 2010 the public certainly **wanted** hugely improved batteries

Which stimulated a renaissance in worldwide battery research

But did we really **need** hugely improved batteries?

*Would our technological society collapse if they did not soon appear?*

*A cynic (e.g., a socially unconnected baby-boomer) might plausibly argue **no***

*But there is now an unequivocal **NEED** for better batteries:*

Climate change threatens not only technological human society

but also non-technological cultures, and indeed the earth's entire biosphere

That assertion is explored at length in the final three note sets of this website:

**Climatology & Climate Change** ([pptx](#) / [pdf](#) / [key](#))

**Greenhouse Effect, Carbon Footprint & Sequestration** ([pptx](#) / [pdf](#) / [key](#))

**Where Do We Go from Here?** ([pptx](#) / [pdf](#) / [key](#))

From those and other note sets on this website, the takeaways are that:

1) **Ground vehicles must eliminate (or hugely decrease) their use of fossil-fuels**

With the obvious alternative being a switch to the use of **BATTERY** power

*(Plausible alternatives for sea & air vehicles are NOT similarly obvious,*

*for reasons that will be explained later in this note set)*

2) **Those batteries must be charged from non-fossil fuel power sources**

3) **Electrical power in general must eliminate (or hugely decrease) use of fossil-fuels**

## *But that will require more than just improved vehicle batteries*

Why? Because the sun sets and winds die down

Daily sunlight energy cycles:

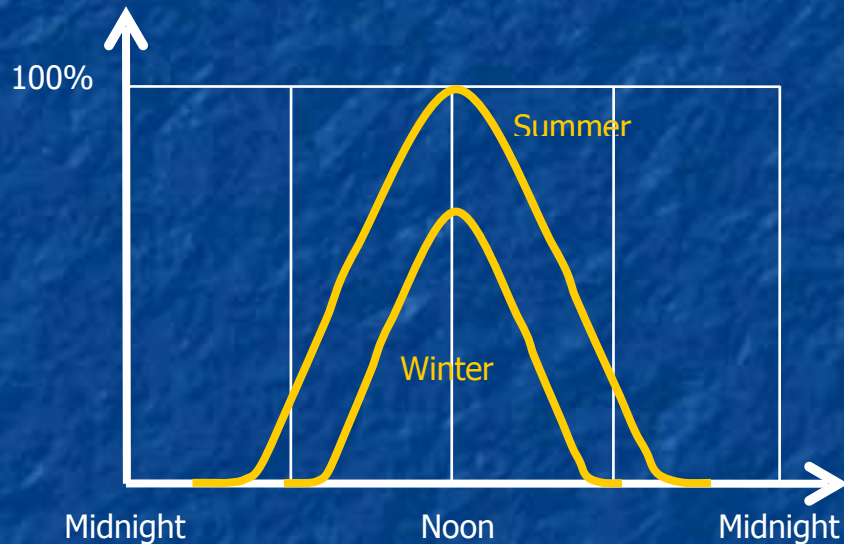

Typical wind energy cycle:

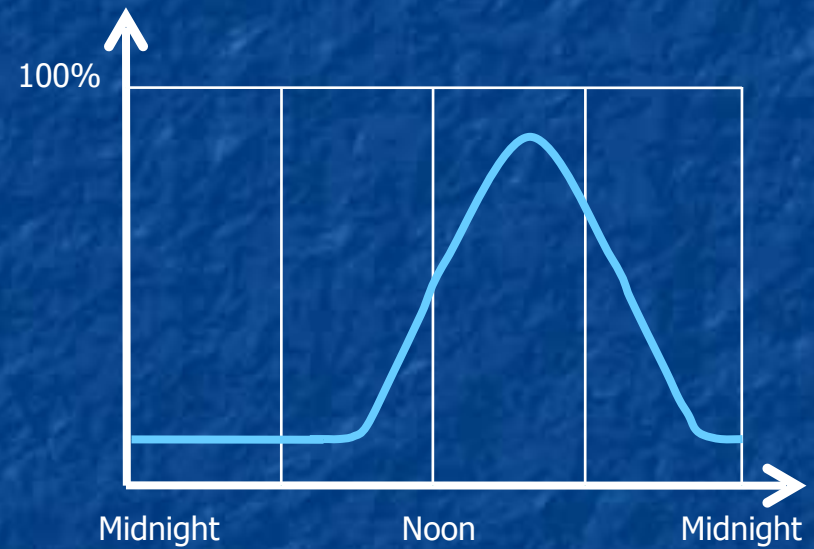

Which means that, in a Grid built largely around solar and wind energy,  
when the sun is up, or the winds are strong,

**we will have to store a whole lot of power for use at other times in the day**

# *Green Grid = Green Energy Sources + Massive Energy Storage*

This is discussed further in my note set:

## **Power Cycles & Energy Storage** ([pptx](#) / [pdf](#) / [key](#))

It includes discussion of alternatives to battery energy storage now being explored

But batteries remain our best developed & most versatile present day alternative

Further, for applications where weight and/or size are critical (e.g., most types of vehicle),

batteries (or closely related fuel cells) have clear and outstanding advantages

**Battery technology & research are thus very much "back on my radar"**

And in this note set I will share what I have now learned (and continue to learn)

This includes getting into details that were glossed over in my chemistry classes:

Details that are now crucial for increasing battery energy capacity & charging speed

Details that also affect things like the probability of a battery bursting into flames

***From my newly motivated interest in batteries, let me begin with:***



# ***A Brief Review of Battery History***

# Starting with: What WAS going on in the batteries taught about in school?

Including the 2000 year old **Baghdad Battery**: <sup>1</sup>

The artifacts: <sup>2</sup>



Their likely operating mode: <sup>3</sup>

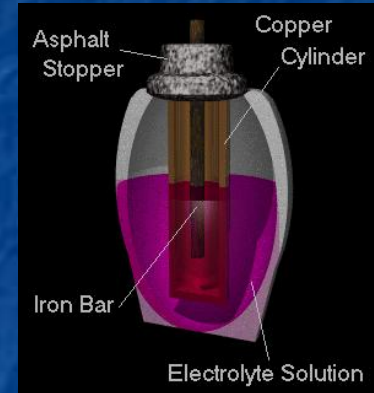

Elementary school's **citrus fruit battery**: <sup>4</sup>

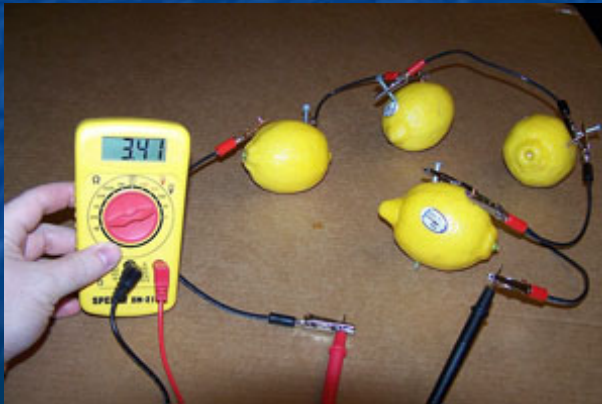

High school's **salt bridge battery**: <sup>5</sup>

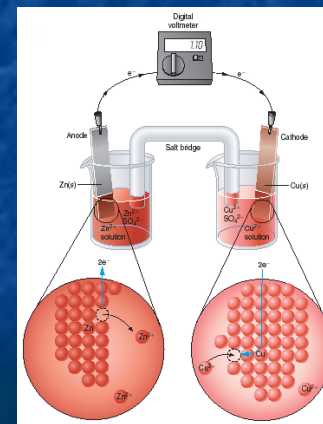

1) [https://en.wikipedia.org/wiki/Baghdad\\_Battery](https://en.wikipedia.org/wiki/Baghdad_Battery)

2) <https://www.atlasobscura.com/places/bagdad-battery>

3) <http://www.unmuseum.org/bbattery.htm>

4) [http://www.edinformatics.com/math\\_science/how\\_does\\_a\\_battery\\_work.htm](http://www.edinformatics.com/math_science/how_does_a_battery_work.htm)

5) <http://courses.washington.edu/bhchem/c456/ch11.pdf>

*Baghdad & Citrus batteries exploit a dissolving metal + an acid's hydrogen ions*

They thus resemble the "1<sup>st</sup> modern battery" invented by Alessandro Volta in 1800: <sup>1</sup>

(After whom our unit of electrical potential, Volts, was named)

In it, atoms from a zinc metal **anode** dissolved as ions in an acid:

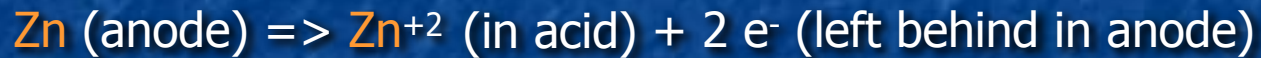

Those electrons flowed out of the anode & back into a metal **cathode**,

where they attracted the acid's hydrogen ions to form H<sub>2</sub> gas molecules:



**Anode (Zn metal atoms ionizing/dissolving)**



**Cathode (hydrogen de-ionizing/forming H<sub>2</sub> gas)**

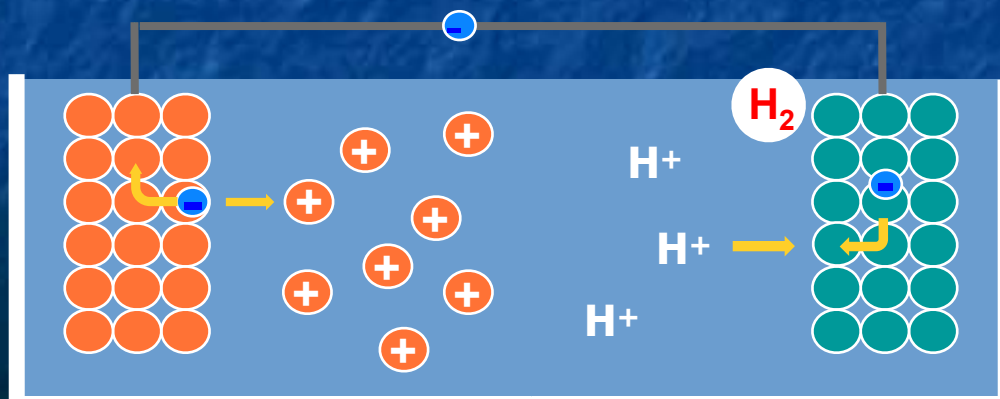

Reference #1 and photo above:  
[http://www.edinformatics.com/math\\_science/how\\_does\\_a\\_battery\\_work.htm](http://www.edinformatics.com/math_science/how_does_a_battery_work.htm)

*Power (electron flow) depended upon ONLY one metal + acid's ions*

Changing the second metal (the one used in the "cathode") has no effect

At least if that second metal does not itself tend to dissolve & ionize in the acid

Power (electron flow) is supplied as long as **BOTH** reactions continue:

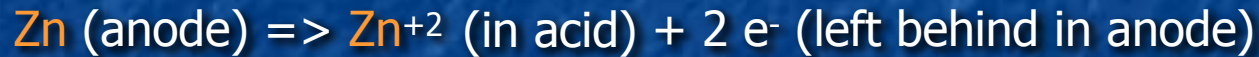

The solid Zn metal anode can supply LOTS of  $\text{Zn}^{+2}$  ions

But the  $\text{H}^+$  ion supply in the acid is very much smaller

**When  $\text{H}^+$  is depleted, power output ceases (the battery is "discharged")**

**Further, forcing electrons backward will NOT recharge this battery**

Because the hydrogen released during discharge cannot be drawn back in

It's permanently lost, floating away as (potentially explosive)  $\text{H}_2$  gas

**These batteries can ONLY be regenerated by pouring in replacement acid**

# A slightly more recognizable battery was invented by Daniell in 1836 <sup>1</sup>

It used Zn and Cu electrodes, each immersed in an electrolyte containing that metal

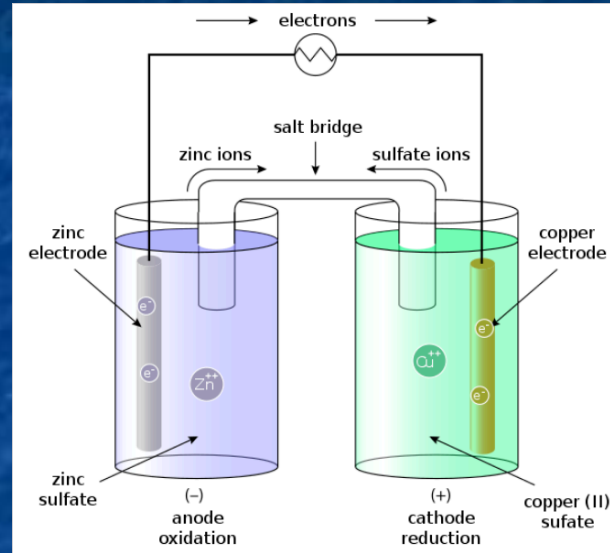

1) [https://en.wikipedia.org/wiki/Daniell\\_cell](https://en.wikipedia.org/wiki/Daniell_cell)

2) [https://en.wikipedia.org/wiki/Salt\\_bridge](https://en.wikipedia.org/wiki/Salt_bridge)

This is the "technology" still featured in many high school Chemistry textbooks

Including its generally unexplained / hopelessly impractical glass "salt bridge"

Which turns out to be an open glass tube filled with gel or stuffed with filter paper

that's been saturated with salts such as KOH, NaCl or KNO<sub>3</sub> <sup>2</sup>

Its supposed role? Passing charge (via the ions within those salts) but blocking

intermixing of the left (ZnSO<sub>4</sub>) and right (CuSO<sub>4</sub>) electrolytes

*In a more modern version, the separator would be a "porous disc"*

Which Chemistry textbooks ALSO generally left unexplained

But for which I found one vendor offering PTFE & polymer fiber versions <sup>1</sup>

Ions supposedly slip through microscopic passages between the disc's fibers

while electrons are blocked by their insulating PTFE <sup>2</sup> & polymer materials

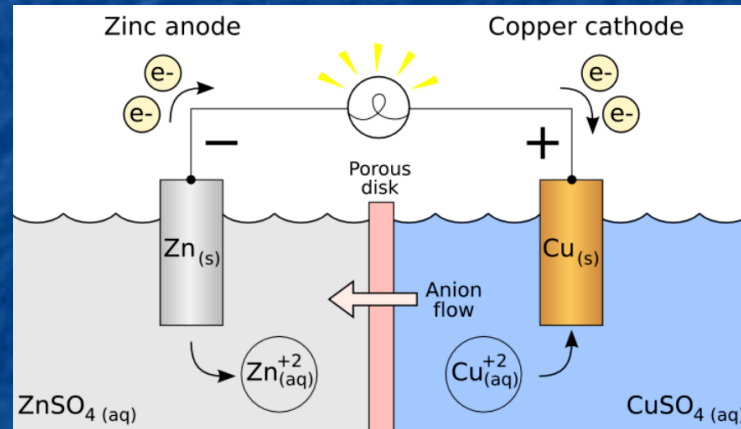

1) <https://www.porex.com/markets/automotive-aerospace/battery-fuel-cell/>

Figure from: [https://en.wikipedia.org/wiki/Galvanic\\_cell](https://en.wikipedia.org/wiki/Galvanic_cell)

**In both "salt bridge" and "porous disc" versions:**

On one side a Zn electrode is immersed in a ZnSO<sub>4</sub> solution ( $\Rightarrow$  Zn<sup>+2</sup> + SO<sub>4</sub><sup>-2</sup>)

On the other a copper electrode is immersed in a CuSO<sub>4</sub> solution ( $\Rightarrow$  Cu<sup>+2</sup> + SO<sub>4</sub><sup>-2</sup>)

2) PTFE's trade name: "Teflon"

*On each side, you can see how the battery action gets **started**:*

On the left, Zn metal atoms from the anode dissolve into the electrolyte as  $Zn^{+2}$  ions

And the electrons thereby released flow out that electrode into the wire

On the right, electrons returning via the wire flow into the Cu cathode where,

at its surface, they facilitate  $Cu^{+2}$  de-ionization and plating onto that electrode

**But with the only charge flow being electrons rightward,**

**the right half would quickly become net negative (and the left net positive),**

**building an electric field that would soon stop further electron flow**

Zn anode (metal atoms ionizing/dissolving)

Cu cathode (metal atoms de-ionizing/precipitating)



*That's where the center "porous disk" and "anion flow" come in:*

Negative electrons flowing to the right, via the wire, MUST be countered by either:

- Simultaneous movement of negative ions ("anions") back to left OR
- Simultaneous movement of positive ions ("cations") to right

EITHER prevents the build up of NET charge or electric fields

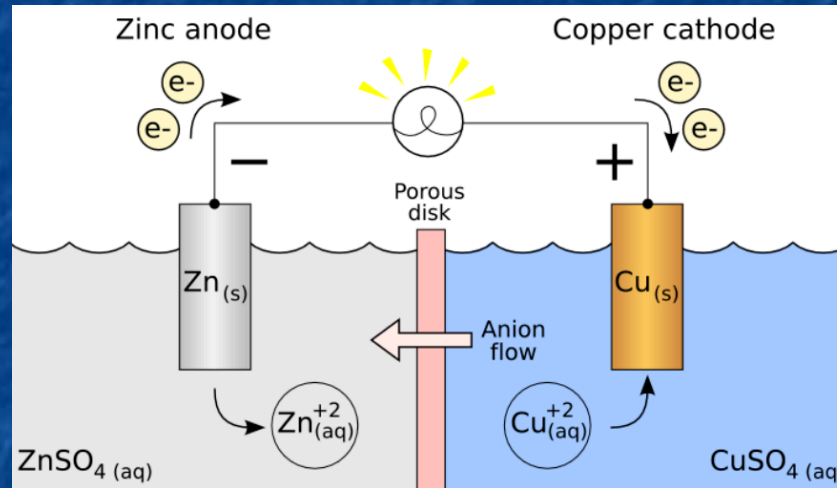

Here the moving ions are leftward negative  $SO_4^{-2}$  ions from the  $CuSO_4$  solution

Negative electrons rightward via wire + Negative  $SO_4^{-2}$  ions leftward via disc

=> Balanced charge flow, allowing continued discharge of this battery



*But what would happen if the porous disk were removed?*

Solutions would mix:

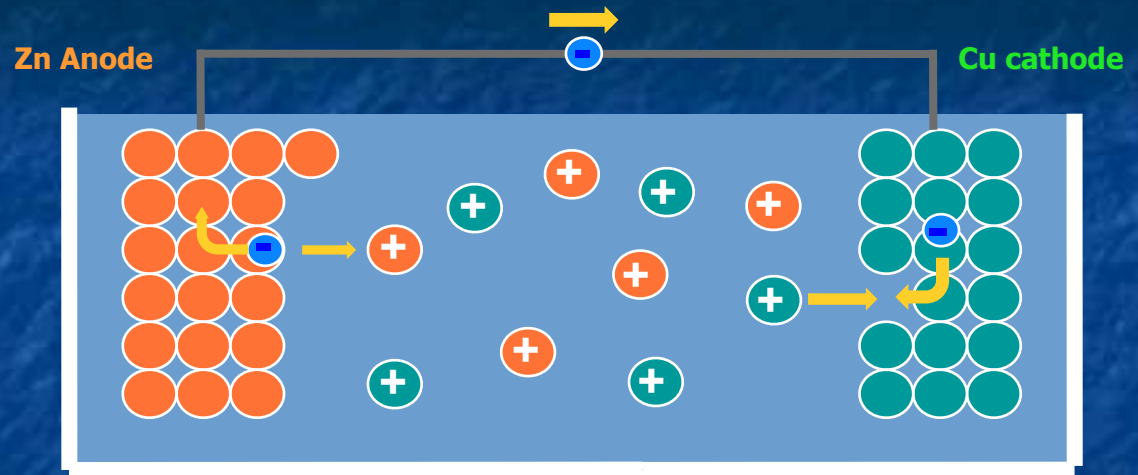

And eventually we'd revert to **local** electron transfer between Zn and Cu atoms/ions



Eliminating electron flow  
out through the wire

Eliminating the "electricity!"

*But we now want a LOT of energy storage per volume or mass:*

So we're not going to be satisfied with spread out structures such as these:

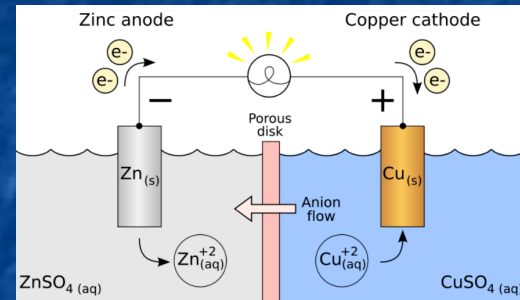
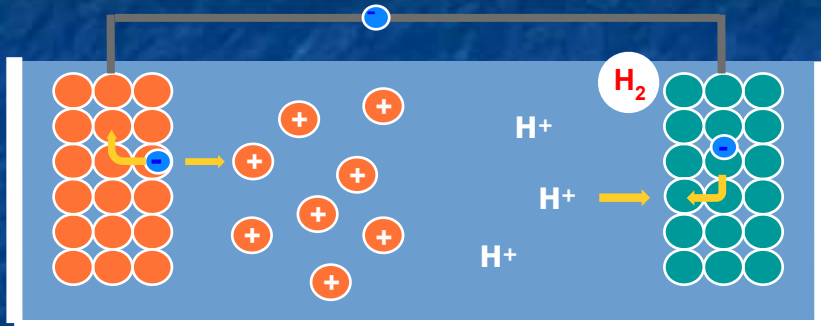

Instead, we're going to move the electrodes as close to one another as possible

**Introducing another potential problem:**

Recharging will require metal ions to come out of solution, back onto the electrodes

On the left, this:

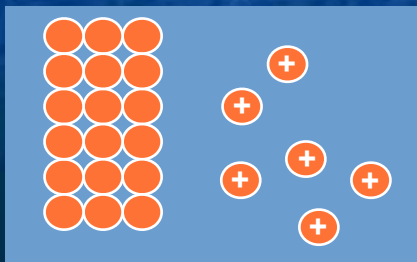

Will have to revert to this:

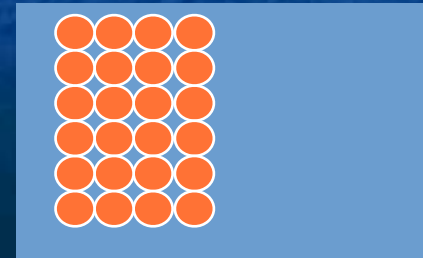

*But that is NOT how crystals (such as metals) usually grow*

Didn't you ever use sugar water to grow sugar crystals?

Pretty crystal spires grow because atoms condense more quickly  
on only **certain** planes of crystal surfaces

=> **dendrites / dendritic growth**



So metal ions re-depositing on electrodes (during recharge) more likely produce:

This:

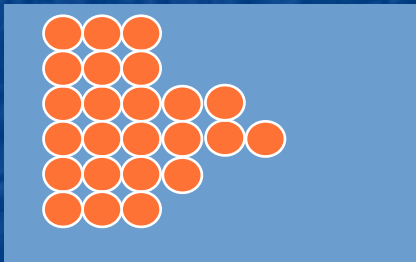

Producing **this** in a new  
more compact battery:

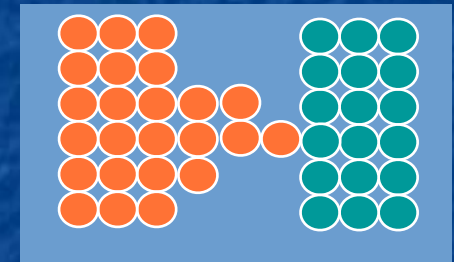

Thus, in a modern denser battery (w/ closely spaced electrodes) recharge can easily:

"Short out" (i.e., permanently & directly connect) the electrodes

Indeed, this is what kills off most of my battery-powered tools!

*Critique of this Daniell battery from a modern energy storage perspective:*

Need for porous disks or glass salt bridge "separators" is finally explained

**Good News:** Because things don't **leave** the cell, and reactions are **reversible**

Recharging now seems possible (at least for this general class of battery)

**Bad News:** Energy Storage Capacity is limited by initial  $\text{Cu}^+$  ion concentration at right

Which (as with Volta's  $\text{H}^+$  ions) can't be all that large

**FURTHER BAD NEWS:**  $\text{Zn}^{+2}$  &  $\text{Cu}^{+2}$  must **eventually** diffuse through the separator

And, indeed, I found certain sources alluding to this

That would occur, I'd guess, within days, weeks or (at most months)

**Suggesting such batteries would die in days, weeks or months**

(Which means that long life batteries **must** be made very differently!)

# ***Battery Science***

*Textbook examples are thus low capacity, impractical, short-lived . . .*

Further, those historical examples leave so many things poorly explained

Such as the very different paths taken by ions and electrons

Such as criteria for choosing electrodes, electrolytes, separators . . .

**To understand Today's battery R&D we need a much more complete  
and intuitive understanding of what is going on deep within them**

Indeed, as someone trained in Applied Physics, who then spent a

career trying to create entirely new / unnatural atomic arrangements

I want to know what is going on right down at their **atomic scale**

Which could provide deep answers to questions such as:

Why do metals fall apart in water as ions and not neutral atoms?

Why don't their liberated electrons also disperse into water?

Why do different metals have different tendencies to fall apart as ions?

## *Those questions reflect my Physics background*

Physicists are obsessed with WHY something happens

Believing that understanding WHY reveals the fundamental laws of Nature

But WHY is easier to figure out for less complex phenomenon (e.g., single atoms)

Leading Physicists to often just ignore more complex phenomenon

Chemists are instead obsessed with HOW to get something working

With "something" (moles & moles of molecules) being HUGELY complex

This drives Chemists towards use of empirical (i.e., observation based) rules

Which have facilitated Chemists' great success in exploiting those complex systems

Even when (according to physicists) understanding of WHY may still be fuzzy

As an APPLIED Physicist, I will now try to find a middle ground by providing explanations

likely offensive to academics & purists in both camps ( . . . *the story of my career* <sup>1, 2</sup>)

**ONWARD!**

# *My explanations revolve around water's exceptional properties*

Chemists refer to water as **The Universal Solvent**

Which exaggerates its abilities . . . but not by much

Water is also known for its "surface tension," manifestations of which include:

high viscosity and a tendency to cling to both itself and to other things

It is also known for the fact that, unlike most liquids, it expands upon freezing

Which all stem from H<sub>2</sub>O's small size plus strong charge imbalances (i.e., **polarization**)

High & left in the periodic table, H holds on to electrons very weakly

High & right in the periodic table, O holds on to electrons very strongly

In Chemistry speak, they're exceptionally **electropositive** & **electronegative**, respectively

As a result, electrons in water's bonds are pulled strongly toward the central O atom:

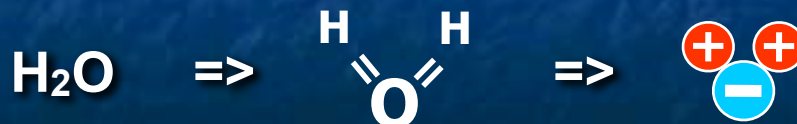



*H<sup>+</sup> 's on one molecule are then attracted to O<sup>=</sup> 's on adjacent molecules*

When ALL H<sup>+</sup>'s lie adjacent to O<sup>=</sup> 's, in 2D this produces:

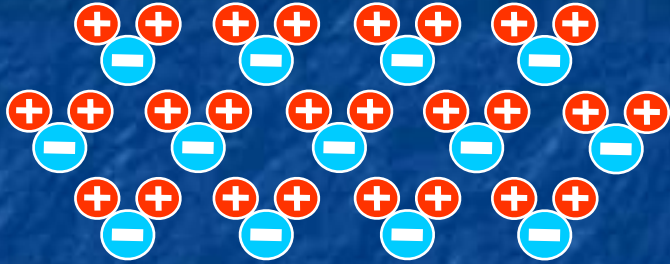

This is the 2D version of water ice which, like its 3D version, has **lots of open space**

At higher temperatures, liquid water molecules continuously jostle around

But as they move they also rotate trying to keep H<sup>+</sup> 's near O<sup>=</sup> 's,

which produces (in 2D) arrangements such as this:



**Such less organized but tightly packed arrangements give liquid water its greater density**

# *Molecular attraction thus explains water's unusually high viscosity*

It also explains why water clings to so many things:

All that's required is that atoms on an object's surface also

have polarized bonds to which water molecules are attracted:

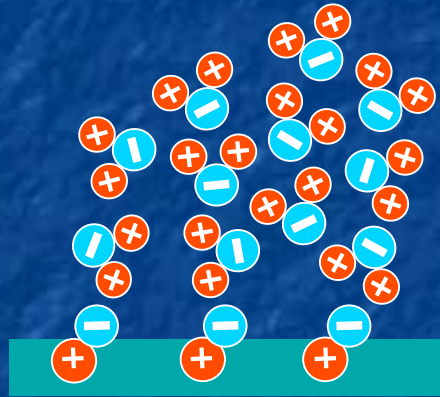

Relevant to batteries, it also means pulling water molecules apart requires energy:

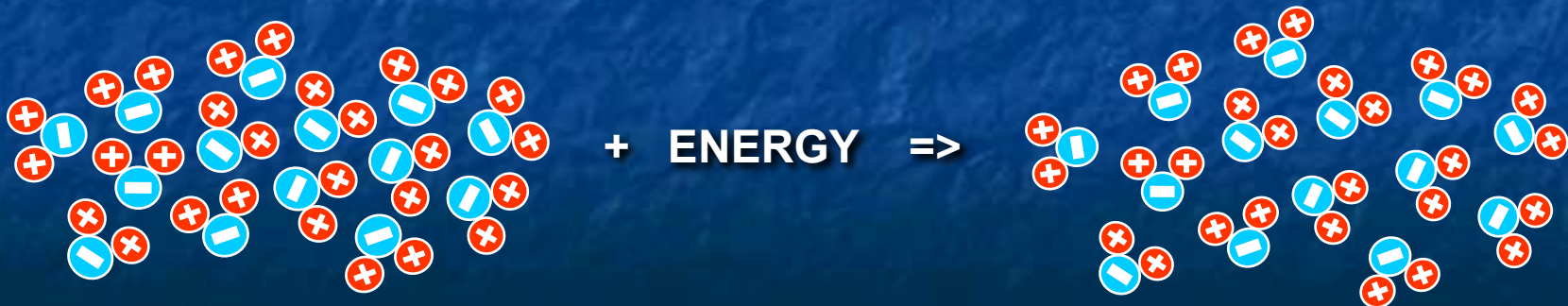

*Energy that would also be required if metals dissolved as neutral atoms*

Because a **neutral metal atom** dissolved in water would NOT attract water molecules  
but it **would** obstruct THEIR ability to draw close to one another



A **charged metal ion** would still push water molecules apart

But its charge would attract water molecules => Lower energy organization

For instance, via tight arrangements such as:



*Ions thus naturally form and move freely in water*

But electrons do not - they need to latch on to an atom (drawn by its positive nucleus)

But in water molecules, the atoms don't tend to latch onto extra electrons

Putting this all together, in contact with water:

IONS tend to be liberated from metallic surfaces BECAUSE

metallic ions are easily created and dispersed in water,

while their abandoned electrons readily disperse into the solid metal

(Or for negative ion formation, electrons are supplied from that metal)

**DISSOLUTION OF METALS IN WATER THUS PROVIDES A NATURAL WAY OF:**

**1) SEPARATING ELECTRONS FROM THEIR PARENT ATOMS**

**2) FORCING LIBERATED ELECTRONS TO TRAVEL DIFFERENT PATHS**

**Which, for batteries, is through wires & useful things in the our world**

## *Bringing me to my third question:*

"Why do different metals have different tendencies to fall apart as ions?"

First, because the different bond strengths within metals means that the initial step of metal-to-metal bond breaking requires different energies

Second, because liberated metal ions have different sizes and charge configurations, so inserting liberated ions between water molecules requires different energies

The process of two different metals dissolving as positive ions in water:



Would thus be described by chemical reactions:



Where the net  $\Delta E$ 's would almost certainly be different

These "Redox half reactions" are tabulated in Chemistry textbooks

But those tables must deal with metals that dissolve as positive ions,

and metals that dissolve as negative ions,

and metals that can have multiple ionic charge states

Their reactions are thus consistently listed showing left to right

addition of electrons to the metal, which Chemists term **REDUCTION**

(as opposed to loss of electrons, which Chemists term **OXIDATION**)

Table 1. Standard Reduction Potentials.

Half-Reaction	E°(Volts)
$F_2(g) + 2e^- \rightarrow 2F^-(aq)$	+2.87
$Cl_2(g) + 2e^- \rightarrow 2Cl^-(aq)$	+1.36
$Br_2(l) + 2e^- \rightarrow 2Br^-(aq)$	+1.07
$Ag^+(aq) + e^- \rightarrow Ag(s)$	+0.80
$Fe^{3+}(aq) + e^- \rightarrow Fe^{2+}(aq)$	+0.77
$Cu^{2+}(aq) + 2e^- \rightarrow Cu(s)$	+0.34
$2H^+(aq) + 2e^- \rightarrow H_2(g)$	0.00
$Fe^{2+}(aq) + 2e^- \rightarrow Fe(s)$	-0.44
$Zn^{2+}(aq) + 2e^- \rightarrow Zn(s)$	-0.76
$Al^{3+}(aq) + 3e^- \rightarrow Al(s)$	-1.66
$Mg^{2+}(aq) + 2e^- \rightarrow Mg(s)$	-2.37
$Ca^{2+}(aq) + 2e^- \rightarrow Ca(s)$	-2.87
$K^+(aq) + e^- \rightarrow K(s)$	-2.93

This table is from:  
<https://www.chegg.com/homework-help/questions-and-answers/use-table-1-determine-2-half-reactions-standard-reduction-potentials-redox-reaction-occu-q9429859>

*And aha! The  $E^\circ$  's must refer to the energy thereby released!*

No, that's the Physicist in me jumping to a premature conclusion

Higher  $E^\circ$  values DO reflect a greater tendency of those reactions to proceed

But Chemists label these **Redox HALF reactions** because they cannot occur alone

Electrons MUST end up moving from one atom to another atom

Thus, in the bigger picture (such as a real world battery)

a rightward half reaction MUST BE COUPLED with a leftward half reaction

One such coupling would be:  $\text{Cu}^{+2} + 2 \text{e}^- \rightleftharpoons \text{Cu}$  with:  $\text{Zn} \rightleftharpoons \text{Zn}^{+2} + 2 \text{e}^-$

Adding these together yields a FULL atom-to-atom charge transfer reaction

*(where, because  $2\text{e}^-$  then appears on both sides, it cancels out):*<sup>1</sup>



1) Chemistry sources can't make up their mind about how to express an ion's charge, e.g.,  $\text{Cu}^{+2}$  vs.  $\text{Cu}^{2+}$   
In my own text and figures I'll just stick with the Physicist's convention of sign then number, e.g.,  $\text{Cu}^{+2}$

# Significance & utility of those $E^\circ$ half reaction "Reduction Potentials?"

Sticking with the example of coupled copper and zinc, the table's entries were:



But we inverted the second reaction, which flips the sign on its  $E^\circ$



These are then added together to yield a full charge transfer reaction of:



**1.10 V** is the number with real world significance:

To a Physicist, it's the transferred electrons' change in potential energy / q

Where q = the charge carried by an electron =  $1.6 \times 10^{-19}$  Coulombs

To a Chemist, it's the Voltage established between the Cu and Zn electrodes

1) For a more extensive explanation I recommend these two sources:

[https://en.wikipedia.org/wiki/Galvanic\\_cell](https://en.wikipedia.org/wiki/Galvanic_cell)

<https://www.britannica.com/science/oxidation-reduction-reaction/Redox-potentials-for-common-half-reactions>



*To which one qualifier + one elaboration must be added: 1, 2*

Qualifier: Tabulated half reaction  $E^\circ$  potentials assume **1 molar** ion concentrations

For other ion concentrations  $E^\circ$ 's shift according to the **Nernst Equation** <sup>3</sup>

Elaboration: Combined  $E^\circ$  half potentials => Change in electron **potential energy**

But while **kinetic energy** is absolutely defined by the equation  $1/2 mv^2$

Potential energies are not absolute, and are only manifested by their change

e.g., by the change in gravitational energy when an object rises or falls

$E^\circ$  **half** potentials are similarly not absolutely defined, instead:

The half reaction  $2 H^+ + 2 e^- = H_2$  is **arbitrarily** assigned  $E^\circ = 0.0$  Volts

A Metal's  $E^\circ$  is then defined as the voltage from a cell combining an

electrode of that metal with a "Hydrogen reference electrode" <sup>2, 4</sup>

1) [https://en.wikipedia.org/wiki/Galvanic\\_cell](https://en.wikipedia.org/wiki/Galvanic_cell)

2) <https://www.britannica.com/science/oxidation-reduction-reaction/Redox-potentials-for-common-half-reactions>

3) [https://en.wikipedia.org/wiki/Nernst\\_equation](https://en.wikipedia.org/wiki/Nernst_equation)

4) <https://courses.lumenlearning.com/boundless-chemistry/chapter/standard-reduction-potentials/>

# ***Batteries in TODAY's homes & ground vehicles***

## **The Rechargeable *Lead Acid Battery* <sup>1</sup>**

Which accounts for nearly one half of **today's** worldwide batteries

Despite being invented in 1859 (not long after Volta's & Daniell's batteries)

**As in other batteries that follow, somewhat conductive metal oxides play a key role:**

Lead Acid batteries use Pb as one electrode and PbO<sub>2</sub> as the other

These are separated by a sulfuric acid **electrolyte** (H<sub>2</sub>SO<sub>4</sub> => 2 H<sup>+</sup> + SO<sub>4</sub><sup>-2</sup>)

During discharge, at the somewhat porous / spongy lead anode: <sup>2</sup>

Pb is released as ions: 
$$\text{Pb(s)} \Rightarrow \text{Pb}^{+2}(\text{aq}) + 2 \text{e}^{-}$$

Which react with the acid's SO<sub>4</sub><sup>-2</sup>: 
$$\text{Pb}^{+2}(\text{aq}) + \text{SO}_4^{-2} \Rightarrow \text{PbSO}_4(\text{s})$$

That PbSO<sub>4</sub> solid then precipitates onto the anode's surface

Yielding a combined effective anode half reaction (which is here already reversed):

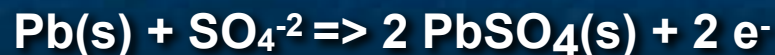

1) [https://en.wikipedia.org/wiki/Lead-acid\\_battery](https://en.wikipedia.org/wiki/Lead-acid_battery)

2) <https://www.usetute.com.au/pbbattery.html>

## *The cathode discharge half reaction is also multi-step:*

The charged cathode consists of solid lead dioxide,  $\text{PbO}_2(\text{s})$ , on top of a lead core

During discharge: <sup>1</sup>



That  $\text{PbSO}_4(\text{s})$  then precipitates onto the cathode's surface

Yielding a combined effective cathode half reaction of:



Adding anode and cathode half reactions yields the full cell discharge reaction:



This battery's discharge converts BOTH the **Pb anode** into  **$\text{PbSO}_4(\text{s})$  on a Pb core**

AND the  **$\text{PbO}_2$  on a Pb core cathode** into  **$\text{PbSO}_4(\text{s})$  on a Pb core**

1) This is again based on the ONLY website I found providing a COMPLETE view of this battery's inner workings:  
AUS-e-TUTE.com.au's <https://www.usetute.com.au/pbbattery.html>

## *Those reactions are unusually complex*

Ease of fabrication may thus explain the very early invention of Lead Acid batteries

Their fabrication begins with obtaining two IDENTICAL lead plates:

Which is easy because we've mined & refined lead for thousands of years

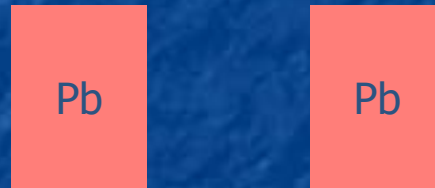

Next obtain sulfuric acid which, because it forms naturally from water + sulfurous rocks,

has ALSO been known and exploited by man for thousands of years

Immerse one of the lead plates in the sulfuric acid (along with a different metal electrode)

Apply a positive voltage to the lead, driving the reaction:



Repeat that process with the other lead plate, leaving you with:

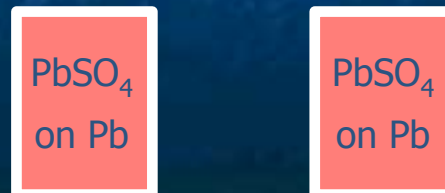

With a gap between those two  $\text{PbSO}_4$  on Pb plates, immerse both in weak sulfuric acid:

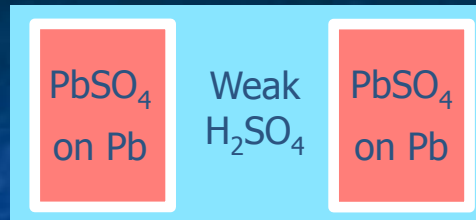

(Discharged)

Apply negative voltage to the left plate, driving its surface back to pure lead:



As the positive voltage on the right plate drives its surface from  $\text{PbSO}_4$  to  $\text{PbO}_2$ :



Both reactions liberate  $\text{HSO}_4^-$  which converts the formerly weak acid to strong acid

**The result is a fully charged Lead Acid battery, ready for use:**

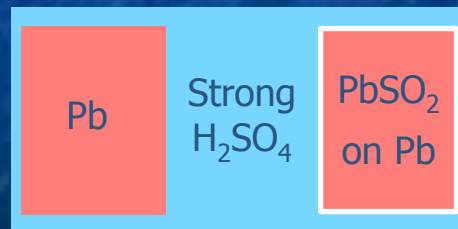

(Charged)

Discharge reverses those reactions, restoring the battery to the upper configuration

## *Two ancient technologies: Lead + Sulfuric acid*

Which likely explains why the Lead Acid battery could be invented as early as 1859

Nevertheless, when six such cells are connected within a plastic box

you get the 20<sup>th</sup> century **12 Volt** battery that still starts our cars

or the 21st century battery that still stores the energy from

a substantial fraction of our **rooftop solar cell arrays**



But Lead Acid battery energy storage per weight or volume is **not** particularly high: <sup>1</sup>

Energy / mass = 33-42 W-h / kg      Energy / volume = 60-110 W-h / liter

And Pb-Acid batteries **do** use (and require the mining and disposal of) **toxic lead**

But this is mitigated by they're also being **the world's most recycled battery**:

*"In the United States 99% of all battery lead was recycled between 2009 and 2013" <sup>1</sup>*

Reference 1 and figure: [https://en.wikipedia.org/wiki/Lead-acid\\_battery](https://en.wikipedia.org/wiki/Lead-acid_battery)

# Expanded list of Reduction half reactions **including metal oxides**

## Standard Potentials at 25°C

Half Reaction	Potential
$F_2 + 2e^- \rightarrow 2F^-$	+2.87 V
$O_3 + 2H^+ + 2e^- \rightarrow O_2 + H_2O$	+2.07 V
$S_2O_8^{2-} + 2e^- \rightarrow 2SO_4^{2-}$	+2.05 V
$PbO_2 + 4H^+ + SO_4^{2-} + 2e^- \rightarrow PbSO_4 + 2H_2O$	+1.69 V
$Au^+ + e^- \rightarrow Au$	+1.69 V
$Pb^{4+} + 2e^- \rightarrow Pb^{2+}$	+1.67 V
$2 HClO + 2H^+ + 2e^- \rightarrow Cl_2 + 2H_2O$	+1.63 V
$Ce^{4+} + e^- \rightarrow Ce^{3+}$	+1.61 V
$MnO_4^- + 8H^+ + 5e^- \rightarrow Mn^{2+} + 4H_2O$	+1.51 V
$Au^{3+} + 3e^- \rightarrow Au$	+1.40 V
$Cl_2 + 2e^- \rightarrow 2Cl^-$	+1.36 V
$Cr_2O_7^{2-} + 14H^+ + 6e^- \rightarrow 2Cr^{3+} + 7H_2O$	+1.33 V
$O_2 + 4H^+ + 4e^- \rightarrow 2H_2O$	+1.23 V
$MnO_2 + 4H^+ + 2e^- \rightarrow Mn^{2+} + 2H_2O$	+1.21 V
$Pt^{2+} + 2e^- \rightarrow Pt$	+1.20 V
$Br_2 + 2e^- \rightarrow 2Br^-$	+1.09 V
$2Hg^{2+} + 2e^- \rightarrow Hg_2^{2+}$	+0.92 V
$ClO^- + H_2O + 2e^- \rightarrow Cl^- + 2OH^-$	+0.89 V
$Ag^+ + e^- \rightarrow Ag$	+0.80 V
$Hg_2^{2+} + 2e^- \rightarrow 2Hg$	+0.79 V
$Fe^{3+} + e^- \rightarrow Fe^{2+}$	+0.77 V
$MnO_4^- + 2H_2O + 3e^- \rightarrow MnO_2 + 4OH^-$	+0.60 V
$I_2 + 2e^- \rightarrow 2I^-$	+0.54 V
$O_2 + 2H_2O + 4e^- \rightarrow 4OH^-$	+0.40 V
$Cu^{2+} + 2e^- \rightarrow Cu$	+0.34 V
$Hg_2Cl_2 + 2e^- \rightarrow 2Hg + 2Cl^-$	+0.27 V
$AgCl + e^- \rightarrow Ag + Cl^-$	+0.22 V
$NO_3^- + H_2O + 2e^- \rightarrow NO_2^- + 2OH^-$	+0.01 V
$2H^+ + 2e^- \rightarrow H_2$	0.000 V

← As in Lead-Acid

← As in Zn-C & Alkalines

←

←

Half Reaction	Potential
$2H^+ + 2e^- \rightarrow H_2$	0.000 V
$Fe^{3+} + 3e^- \rightarrow Fe$	-0.04 V
$Pb^{2+} + 2e^- \rightarrow Pb$	-0.13 V
$Sn^{2+} + 2e^- \rightarrow Sn$	-0.14 V
$Ni^{2+} + 2e^- \rightarrow Ni$	-0.23 V
$V^{3+} + e^- \rightarrow V^{2+}$	-0.26 V
$Co^{2+} + 2e^- \rightarrow Co$	-0.28 V
$In^{3+} + 3e^- \rightarrow In$	-0.34 V
$PbSO_4 + 2e^- \rightarrow Pb + SO_4^{2-}$	-0.36 V
$Cd^{2+} + 2e^- \rightarrow Cd$	-0.40 V
$Cr^{3+} + e^- \rightarrow Cr^{2+}$	-0.41 V
$Fe^{2+} + 2e^- \rightarrow Fe$	-0.44 V
$Zn^{2+} + 2e^- \rightarrow Zn$	-0.76 V
$2H_2O + 2e^- \rightarrow H_2 + 2OH^-$	-0.83 V
$Cr^{2+} + 2e^- \rightarrow Cr$	-0.91 V
$Mn^{2+} + 2e^- \rightarrow Mn$	-1.18 V
$V^{2+} + 2e^- \rightarrow V$	-1.19 V
$ZnS + 2e^- \rightarrow Zn + S^{2-}$	-1.44 V
$Al^{3+} + 3e^- \rightarrow Al$	-1.66 V
$Mg^{2+} + 2e^- \rightarrow Mg$	-2.36 V
$Na^+ + e^- \rightarrow Na$	-2.71 V
$K^+ + e^- \rightarrow K$	-2.92 V
$Li^+ + e^- \rightarrow Li$	-3.05 V

←

←

←

From:

<http://ch302.cm.utexas.edu/echem/echem-cells/selector.php?name=std-red-potentials>

Which, in turn, was drawn from a vastly longer Wikipedia listing:  
[https://en.wikipedia.org/wiki/Standard\\_electrode\\_potential\\_\(data\\_page\)](https://en.wikipedia.org/wiki/Standard_electrode_potential_(data_page))



## The Non-Rechargeable "**Zinc Carbon**" Battery <sup>1</sup>

It's actually based on **Zinc & Manganese Oxide** (with carbon playing only a minor role)

A **wet** version using  $\text{NH}_4\text{Cl}$  electrolyte was developed by LeLanche in 1876

A **dry** version changed the electrolyte to a water-based paste in 1886

**That version went on to power the world's first flashlight**

Today's **heavy duty / dry** version uses an electrolyte of  $\text{NH}_4\text{Cl}$  **plus**  $\text{ZnCl}_2$

At the literal **core** of the "dry" versions is **carbon powder**,

but it is surrounded by wet paper impregnated with  **$\text{MnO}_2$  powder**

That  **$\text{MnO}_2$**  provides the cathode's electrochemically reactive surface

(and is thus the TRUE cathode material)

The anode is the battery's outer Zinc metal case

The separating electrolyte is  $\text{NH}_4\text{Cl}$  or  $\text{NH}_4\text{Cl} + \text{ZnCl}_2$  paste:

1) [https://en.wikipedia.org/wiki/Zinc%E2%80%93carbon\\_battery](https://en.wikipedia.org/wiki/Zinc%E2%80%93carbon_battery)

Figure adapted from: <https://www.diligentshopper.com/primary-batteries-types-and-performance/>

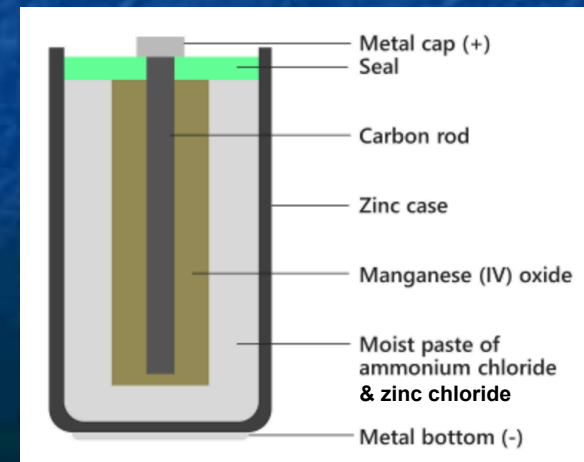

# *Pinning down this battery's exact chemistry is surprisingly difficult:*

Confusion is produced by the (often ignored) multiplicity of versions:

"Wet" with  $\text{NH}_4\text{Cl}$  vs. "Dry" with  $\text{NH}_4\text{Cl}$  vs. "Dry" with  $\text{NH}_4\text{Cl}$  and  $\text{ZnCl}_2$

And by the failure of many/most academic & tutorial websites to even acknowledge

any but the oldest / now hopelessly dated and obsolete 1876 "wet" version

And by the fact that, within the newest Dry /  $\text{NH}_4\text{Cl}$  +  $\text{ZnCl}_2$  / Heavy Duty version,

both  $\text{H}_2$  and  $\text{NH}_3$  gases are produced which, within the sealed battery,

then reabsorb via secondary reactions with the  $\text{Zn}$ ,  $\text{MnO}_2$  & electrolytes

And by the fact that scientists are **still arguing** about those secondary reactions

From three such websites <sup>1-3</sup> the incomplete/semi-obvious Anode & Cathode reactions were:

Anode:  $\text{Zn(s)} \Rightarrow \text{Zn}^{+2} + 2 \text{e}^-$

Cathode:  $\text{MnO}_2 + 2\text{e}^- \Rightarrow \text{Mn}_2\text{O}_3$

But concerning the omitted details, for not one of the three Zn-C battery versions

could I seem to get even two of those three websites to fully agree!

1) Wikipedia: [https://en.wikipedia.org/wiki/Zinc%E2%80%93carbon\\_battery](https://en.wikipedia.org/wiki/Zinc%E2%80%93carbon_battery)

2) Cambridge University: [https://www.doitpoms.ac.uk/tlplib/batteries/batteries\\_zn\\_c.php](https://www.doitpoms.ac.uk/tlplib/batteries/batteries_zn_c.php)

3) Electrical4U.com: <https://www.electrical4u.com/zinc-carbon-battery/>

*Thus focusing on only points of apparent agreement:*

**Regarding the more modern "dry" versions of "Zinc-Carbon" battery:**

Discharge converts the Cathode's  $\text{MnO}_2$  to  $\text{Mn}_2\text{O}_3$

And, at least along the way, discharge converts the Anode's Zn to  $\text{Zn}^{+2}$

During discharge battery output drifts significantly downward thru **1.5 Volts**

Once discharged, a Zn-C battery **cannot be recharged**

Making it a **Primary / Charged-as-built / Single-use** battery

Sitting on a shelf (awaiting that single use) Zn-C batteries **last only 1-2 years**

**Zinc-Carbon batteries enabled the 1<sup>st</sup> generation of portable electronic devices**

But the stunning success & popularity of those devices only highlighted

the shortcomings of the Zn-C batteries upon which they depended

**Which stimulated R&D on whole new types of batteries including:**

## Your Home's Premium Disposable Battery:

# The Non-Rechargeable **Alkaline Battery**

Early versions echoed the "Zinc Carbon" battery by also exploiting Zn and  $\text{MnO}_2$  which were **both** used in the form of wet compacted powders:

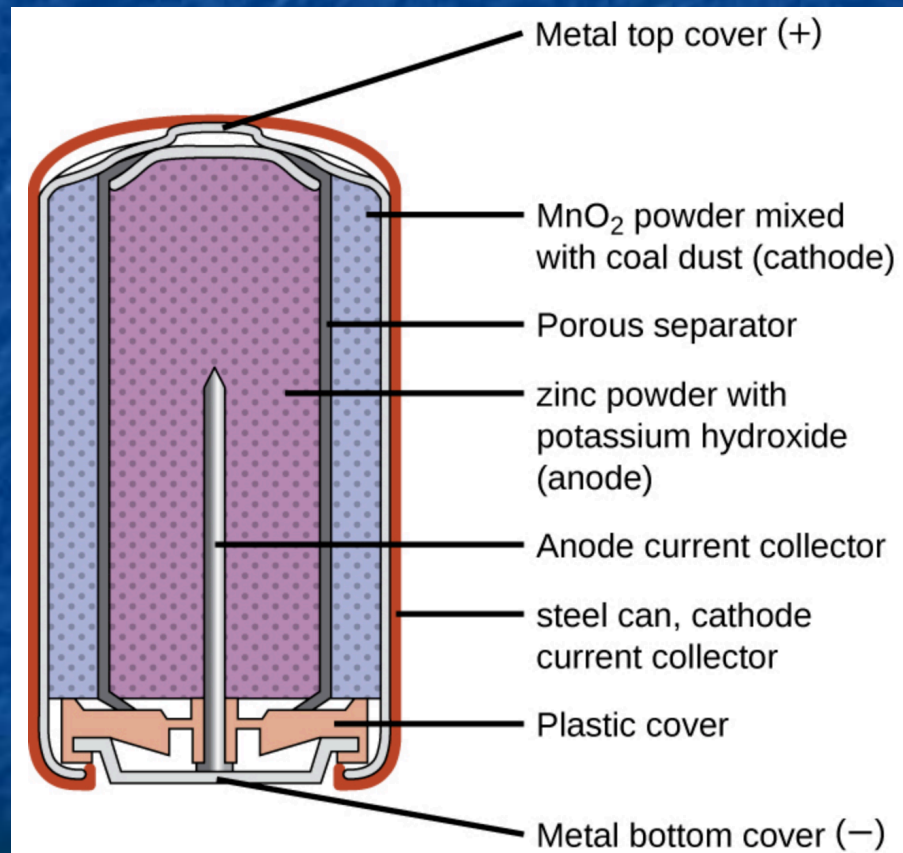

Figure: <https://opentextbc.ca/chemistry/chapter/17-5-batteries-and-fuel-cells/>

*But alkaline KOH electrolyte dramatically changed the inner workings:*

With this chemistry, only OH<sup>-</sup> ions move between the anode and cathode

And metal is neither dissolved from, nor deposited on, those electrodes

Instead, as seen in my simplified representation:

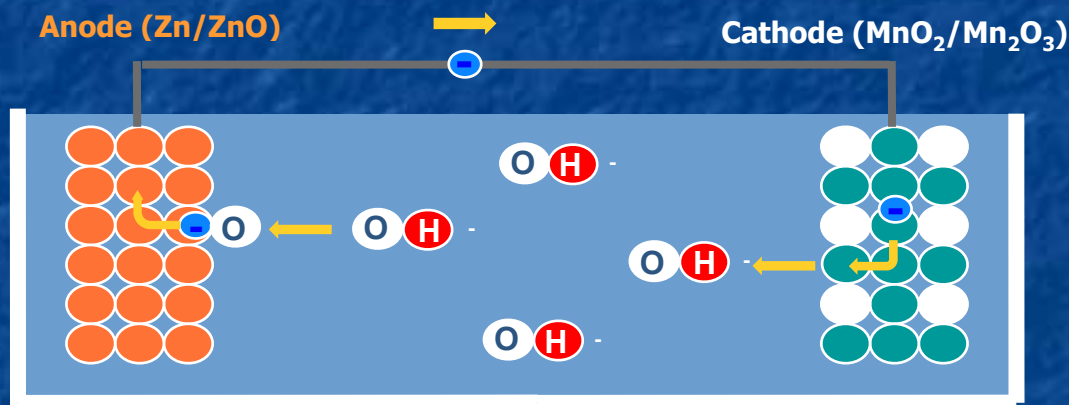

During discharge the left Zn anode's surface **literally** oxidizes:



With that oxygen coming from atoms **leached out** of the MnO<sub>2</sub> cathode:



And then transported via the OH<sup>-</sup> ions in the alkaline KOH electrolyte

## Using Zn and MnO<sub>2</sub>:

This **Alkaline Battery** has the same **1.5 Volt** output as the **Zinc-Carbon Battery**

But the Alkaline Battery has a **longer shelf-life** (up to 10 years vs. Zn-C's 1-2 years) <sup>1</sup>

Further, it stores significantly **more energy per battery mass**,

which is explained by its use of both dense MnO<sub>2</sub> and its

elimination of the Zn-C's wet-paper-wrapped carbon powder core <sup>2</sup>

**But can these Alkaline Batteries be recharged (unlike their older Zn-C cousins)?**

**Yes and No**

Standard Alkaline batteries can rupture upon attempted recharge

Ruining the battery and releasing its very corrosive KOH electrolyte

But tweaked versions can reportedly withstand a **small number of recharges** <sup>2, 3</sup>

*(Classifying it as a barely / possibly-hazardously rechargeable battery?)*

1) [https://batteryuniversity.com/learn/article/primary\\_batteries](https://batteryuniversity.com/learn/article/primary_batteries)

2) [https://en.wikipedia.org/wiki/Alkaline\\_battery](https://en.wikipedia.org/wiki/Alkaline_battery)

3) [https://batteryuniversity.com/learn/archive/will\\_the\\_reusable\\_alkaline\\_battery\\_have\\_a\\_future](https://batteryuniversity.com/learn/archive/will_the_reusable_alkaline_battery_have_a_future)

## Putting this all together, regarding Zn-MnO<sub>2</sub> Alkaline Batteries:

Wikipedia's "Alkaline Battery" webpage reports that they: <sup>1</sup>

*"Account for 80% of manufactured batteries in the US and over 10 billion individual units produced worldwide.*

*In Japan alkaline batteries account for 46% of all primary (non-rechargeable) <sup>2</sup> battery sales.*

*In Switzerland alkaline batteries account for 68%, in the UK 60% and in the EU 47% of all battery sales including secondary (rechargeable) <sup>2</sup> types.*

*Alkaline batteries contain zinc and manganese dioxide, which can be toxic in higher concentrations. However, compared to other battery types, the toxicity of alkaline batteries is moderate."*

**But that webpage succumbs to the recurrent tendency of mis-naming batteries**

As seen earlier in the mis-naming of **Zn-MnO<sub>2</sub> Batteries** as **Zn-Carbon Batteries**

And seen here in the equating of **Alkaline Battery** with **Zn-MnO<sub>2</sub> Alkaline Battery**,

despite Ni-Cd & Ni-Metal Hydride Batteries ALSO being Alkaline Batteries!

1) [https://en.wikipedia.org/wiki/Alkaline\\_battery](https://en.wikipedia.org/wiki/Alkaline_battery)

2) Parenthetical definitions added

## The Rechargeable **Nickel Cadmium (Ni-Cd) Battery** <sup>1, 2</sup>

Invented in 1899 and which, per my preceding editorial,

really should be called the **Nickel Cadmium (Ni-Cd) Alkaline Battery**

Which now mostly use a "Jelly-roll" spiral of stacked anode, separator & cathode layers

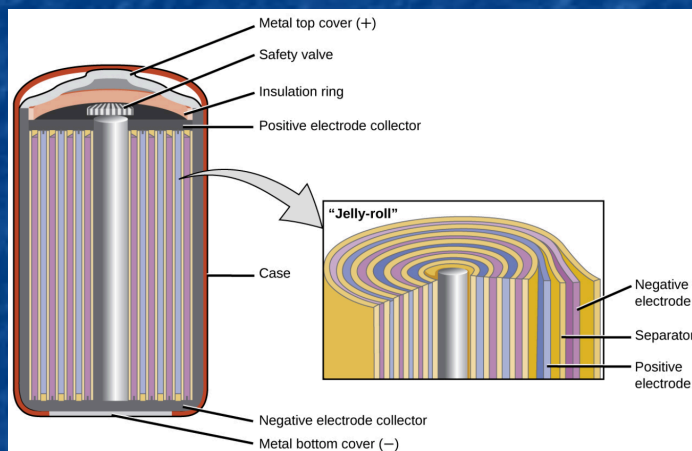

The half reaction within the spiraling cold-pressed-powder anode layer is:



The half reaction within the spiraling "sintered" (hot-pressed-powder) cathode layer is:

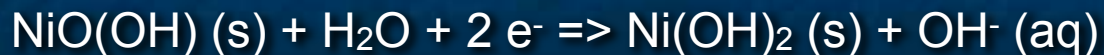



## *Ni-Cd Battery Pluses: 1-4*

They have an **exceptionally long shelf life** <sup>1</sup>

They are **rechargeable as many as two thousand times** <sup>2</sup>

They can be **recharged exceptionally quickly (< 1 hour)** <sup>1</sup>

Once charged, they **remain charged for moderately long periods of time** <sup>2</sup>

During discharge their **voltage output is nearly constant (~ 1.2 Volts / cell)** <sup>2, 3</sup>

During discharge they can **sustain continuous exceptionally high currents** <sup>2, 3</sup>

They are "one of the most **rugged and forgiving** batteries" => Continued airline use <sup>1</sup>

They are the **cheapest battery in terms of lifetime energy delivered** per cost <sup>1</sup>

*Making them the "go-to" power tool battery well into the 21st century* <sup>5</sup>

1) [https://batteryuniversity.com/learn/article/nickel\\_based\\_batteries](https://batteryuniversity.com/learn/article/nickel_based_batteries)    2) [https://en.wikipedia.org/wiki/Nickel%E2%80%93cadmium\\_battery](https://en.wikipedia.org/wiki/Nickel%E2%80%93cadmium_battery)  
3) <https://opentextbc.ca/chemistry/chapter/17-5-batteries-and-fuel-cells/>    4) [https://batteryuniversity.com/learn/archive/memory\\_myth\\_or\\_fact](https://batteryuniversity.com/learn/archive/memory_myth_or_fact)  
5) Here I take issue with Wikipedia based on my decades of home DIY & Habitat for Humanity power tool experience

## *Ni-Cd Battery Minuses: 1-4*

The **cost of their Ni and Cd constituents** is relatively high <sup>1, 2</sup>

Their **self-discharge rate is higher than desirable** for many applications

Their **energy stored per mass is lower than desirable** for many applications

The **toxicity of Cd means that they should not be disposed of in land fills** <sup>1</sup>

Leading to a EU ban for all but replacement & special applications (e.g., medical) <sup>2</sup>

They were reported to exhibit a **Memory Effect: 2, 4**

*"Meaning that a nickel-cadmium battery could remember how much energy was drawn on previous discharges and would not deliver more than was demanded before."* <sup>4</sup>

For which the reported cure is periodic "rejuvenating" full battery discharges

***Degradation (possibly catastrophic) ALSO occurs in batteries about to be discussed***

***So the source of NiCd "Memory" is worth closer examination:***

# *A nanoscale explanation of Ni-Cd battery "Memory:"*

As discussed (and depicted) in a slide far above:

Material leaving an electrode during discharge

Must be driven back onto (or into) that electrode during recharge

**But returning atoms don't naturally lay back down in flat planes**

On crystals they favor only certain planes, leading to growth of **dendrite** spires

As seen for sugar crystals:



Or represented on a battery electrode:

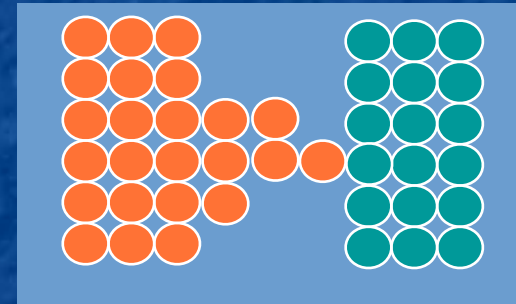

Something similar occurs when  $\text{Cd}(\text{OH})_2$  reforms on a NiCd's anode during recharge:

# As documented on a Battery University Webpage: <sup>1</sup>

Scanning electron micrograph of a new NiCd battery anode:

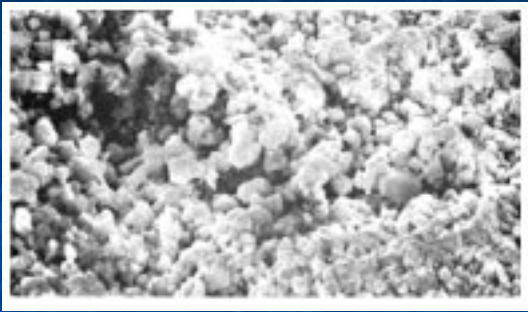

"Hexagonal cadmium-hydroxide crystals are about 1 micron in cross section, exposing large surface area to the electrolyte for maximum performance"

Micrograph of anode after many cycles of battery discharge-recharge:



"Crystals have grown to 50 to 100 microns in cross section, concealing large portions of the active material from the electrolyte. Jagged edges and sharp corners can pierce the separator, leading to increased self-discharge or electrical shorts."

Micrograph of anode after a pulsed charge or deep rejuvenation discharge:

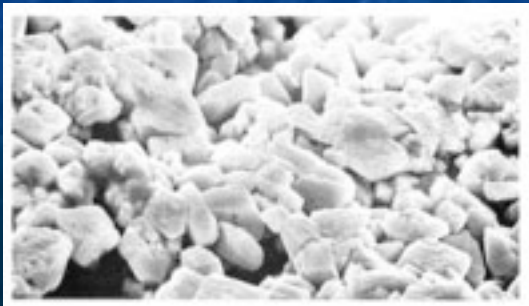

"After a pulsed charge, the crystals are reduced to 3–5 microns, an almost 100% restoration. Exercise or recondition (a.k.a. rejuvenation) is needed if the pulse charge alone is not effective."

1) [https://batteryuniversity.com/learn/archive/memory\\_myth\\_or\\_fact](https://batteryuniversity.com/learn/archive/memory_myth_or_fact)

*Your Home's Newer Reusable Battery:*

## *The Rechargeable **Ni Metal Hydride (NiMH) Battery***

Which is ALSO an "Alkaline Battery" - just using different electrode materials:

**Anode half reaction:**  $M \text{ (solid)} + H_2O + e^- \rightleftharpoons MH \text{ (solid)} + OH^-$

Where metal (M) is some combination of La, Ce, Nd, Pr, Co, Mn, Al, V, Zr or Ni <sup>1</sup>

**Cathode half reaction:**  $Ni(OH)_2 \text{ (solid)} + OH^- \Rightarrow NiO(OH) \text{ (solid)} + H_2O + e^-$

**Electrolyte:** As used in all of these Alkaline Batteries - Potassium Hydroxide

Then representable (via minimal relabeling) by my introductory Alkaline Battery figure:

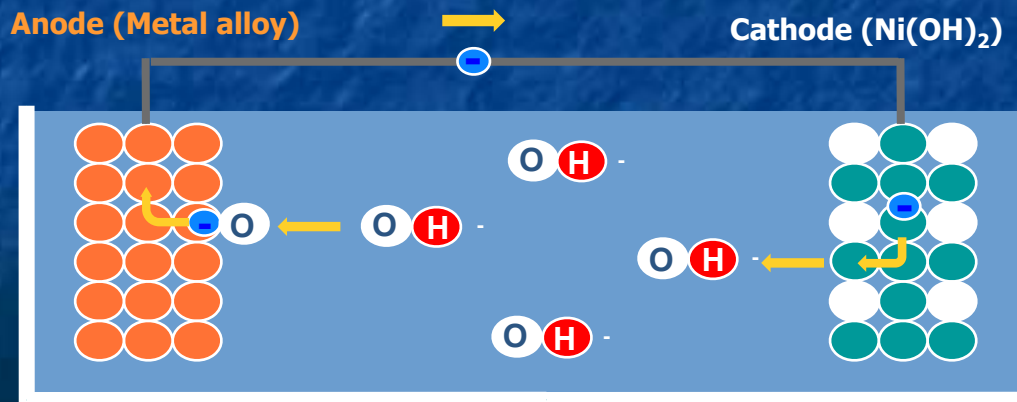

1) [https://en.wikipedia.org/wiki/Nickel%E2%80%93metal\\_hydride\\_battery](https://en.wikipedia.org/wiki/Nickel%E2%80%93metal_hydride_battery)

## NiMH Battery Pluses:

- A **less toxic metal alloy anode** replaces the toxic Cd anode of Ni-Cd Alkaline batteries <sup>1</sup>
- Energy storage capacity is higher** than Ni-Cd's (claims: 50% higher <sup>2</sup> vs. 2-3X higher <sup>1</sup>)
- Their **high energy storage per mass** approaches that of a lithium ion battery <sup>1</sup>
- They **can sustain high output** currents

## NiMH Battery Minuses:

- "More **delicate and trickier to charge** than NiCd" / "**Limited service life**" <sup>2</sup>
- Standard version NiMH batteries have a **high self-discharge rate** <sup>1,2</sup>
- Output declines to 1.0-1.2 Volts** <sup>1</sup> vs. the 1.2-1.5 V of earlier Zn-C & Alkaline batteries
- Consequently: NiMH batteries are **NOT always an acceptable substitute**
- Wikipedia: "**Voltage depression** (often mistakenly attributed to the memory effect) from repeated partial discharge . . . reversible with a few full discharge/charge cycles" <sup>1</sup>
- Battery University: "Less prone to **memory** than NiCd, can be rejuvenated" <sup>2</sup>

1) [https://en.wikipedia.org/wiki/Nickel%E2%80%93metal\\_hydride\\_battery](https://en.wikipedia.org/wiki/Nickel%E2%80%93metal_hydride_battery)

2) [https://batteryuniversity.com/learn/article/nickel\\_based\\_batteries](https://batteryuniversity.com/learn/article/nickel_based_batteries)

# Bringing us to the broad category of **Lithium-Based Batteries** <sup>1</sup>

These batteries increase their output voltage (and hence power)

by pairing electrodes with radically different "electronegativities"

(which is a measure of how strongly a material holds on to its electrons)

Least electronegative (more electropositive) are elements leftmost in Periodic Table

These "Group I" / "Alkali metals" are Li, Na, K, Rb, Cs, Fr

©1998-2003 Synergy Creations

**Electronegativity**  
0.7  4

**Pauling scale**

1																	18				
H 2.1																	He --				
Li 1.0	Be 1.5															B 2.0	C 2.5	N 3.0	O 3.5	F 4.0	Ne --
Na 0.9	Mg 1.2	3	4	5	6	7	8	9	10	11	12	Al 1.5	Si 1.8	P 2.1	S 2.5	Cl 3.0	Ar --				
K 0.8	Ca 1.0	Sc 1.3	Ti 1.5	V 1.6	Cr 1.6	Mn 1.5	Fe 1.8	Co 1.8	Ni 1.8	Cu 1.9	Zn 1.6	Ga 1.6	Ge 1.8	As 2.0	Se 2.4	Br 2.8	Kr 3.0				
Rb 0.8	Sr 1.0	Y 1.2	Zr 1.4	Nb 1.6	Mo 1.8	Tc 1.9	Ru 2.2	Rh 2.2	Pd 2.2	Ag 1.9	Cd 1.7	In 1.7	Sn 1.8	Sb 1.9	Te 2.1	I 2.5	Xe 2.6				
Cs 0.7	Ba 0.9	La 1.1	Hf 1.3	Ta 1.5	W 1.7	Re 1.9	Os 2.2	Ir 2.2	Pt 2.2	Au 2.4	Hg 1.9	Tl 1.8	Pb 1.9	Bi 1.9	Po 2.0	At 2.2	Rn --				
Fr 0.7	Ra 0.9	Ac 1.1	Rf --	Db --	Sg --	Bh --	Hs --	Mt --	Uun --	Uuu --	Uub --	113 --	114 --	115 --	116 --	117 --	118 --				

To maximize battery voltage, those electropositive alkali metals should be paired with a highly electronegative atom (top / right in Periodic Table) or compound

## *Certain pairings can **double** the battery's voltage*

For instance,  $\text{Li} + \text{MnO}_2$  yields a 3.3 Volt battery (vs. 1.0-1.5 Volts of non-Li batteries)

For the same stored charge, that means **twice the stored energy**

Li has another advantage: High in the Periodic Table, it is the **lightest** Alkali Metal

Paired with light cathodes, Li-based batteries will thus be **exceptionally light**

Combining these points: Li-based batteries pack **MUCH more energy per mass**

Making them an obvious choice for portable electronic devices

And a seemingly obvious choice for battery-powered flight (more about that later)

**But now comes the bad news: Oxygen is the second most electronegative element**

Oxygen + alkali metal thus maximizes the energy of electron transfer

But oxygen is lurking all around us (not only in air but in water & its ubiquitous vapor)

**Alkali metals begin to smolder almost immediately in the presence of oxygen**

**Alkali metals burst into flames and/or violently explode in the presence of water**



## Your Home's tiniest batteries:

# The Non-Rechargeable **Lithium Battery / Lithium Metal Battery** <sup>1</sup>

The latter name is more descriptive as it suggests the use of pure Li metal

Which is indeed what is used as the anode in such batteries

Simplified schematic of Li Metal / MnO<sub>2</sub> Battery:

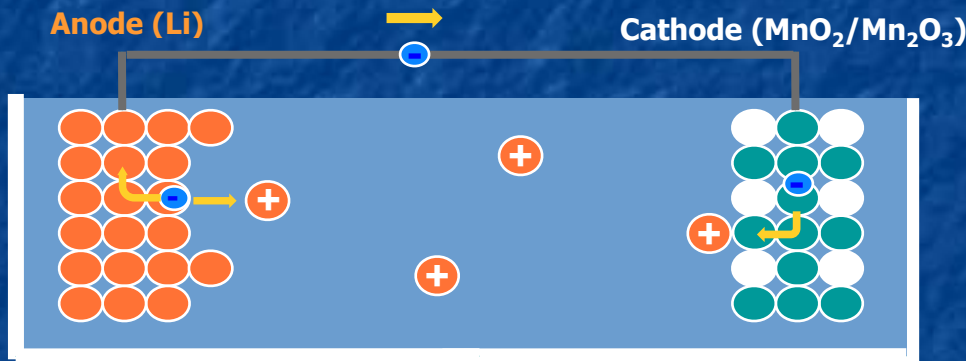

Actual Lithium Metal Batteries: <sup>2</sup>



But the choice of **electrolyte** suddenly becomes very complicated <sup>1</sup>

Because, unlike the electrolytes of ALL the batteries discussed to this point,

**the electrolytes of Li-based batteries MUST NOT contain water**

Instead, **organic solvents** are substituted (which, BTW, are flammable)

In a Li Metal / MnO<sub>2</sub> battery, the electrolyte is LiClO<sub>4</sub> dissolved in C<sub>4</sub>H<sub>6</sub>O<sub>3</sub> <sup>1</sup>

1) [https://en.wikipedia.org/wiki/Lithium\\_battery](https://en.wikipedia.org/wiki/Lithium_battery)

2) <https://learn.adafruit.com/all-about-batteries/lithium-batteries-and-coin-cells>

## *Lithium Metal batteries cannot be safely recharged:*

Because, as Li returns to the anode, it grows **dendrites**

Which, in a practically thin battery, can grow all the way to the cathode

And cannot be reliably blocked even when a **separator** is added

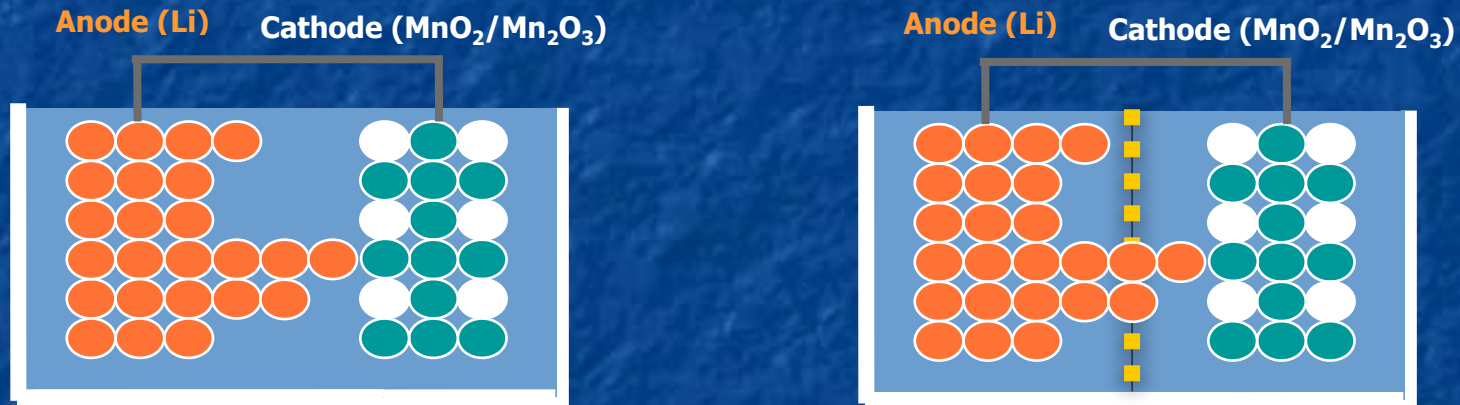

An anode-cathode spanning dendrite would instantaneously discharge the battery

Possibly even liberating enough power to split open it's shell,

which would then additionally allow the organic electrolyte to catch on fire

Li-Metal batteries are thus distinctly **non-rechargeable**

And, for consumer use, they are largely limited to **small button-style batteries**

*Your Home's, Car's, Tool's, Solar Array's . . . Newest Reusable Battery:*

## *A Rechargeable **Lithium-Ion Battery***

The name "Lithium-Ion" distinguishes these from the Lithium Metal batteries, above

But it doesn't actually explain HOW these Li Ion batteries are different

The difference is that these batteries eliminate **pure** Li anodes

and, during discharge, eliminate Li-coated cathode surfaces

**They do this by exploiting Li's exceptionally small size,**

**which gives Li the ability to actually slither INSIDE certain other materials**

Then, **during discharge**, there's more room for Li **inside the cathode** than on its surface,

which **allows the battery to discharge longer / supply more power**

And **during recharge**, going back **inside the anode**, Li dendrites are less likely to form,

which **makes catastrophic short circuits less likely**

Finally, closeted inside anodes & cathodes, Li cannot react as quickly with any invading O<sub>2</sub>,

which means that even if a short circuit does occur,

the **chance of fire, or at least of intense fire, is reduced**

*For the Li-absorbing **Anode**, the common choice is crystalline **Graphite**:*

Graphite is one of carbon's two crystalline forms (the other is diamond)

In Graphite, carbon bonds into planes, which are only weakly attracted to one another

Forming, as shown in this interactive 3D model from my Nanocarbon webpage: <sup>1</sup>

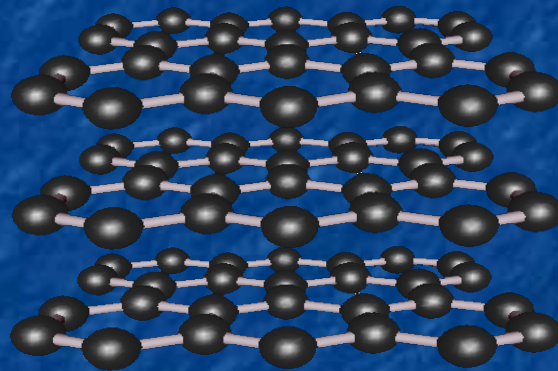

As the anode of a Li-Ion battery, graphite can be represented edge on as:

Li charged anode:

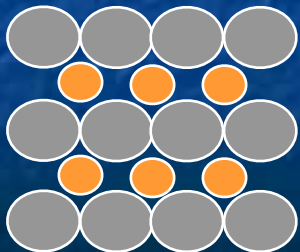

Discharging anode:

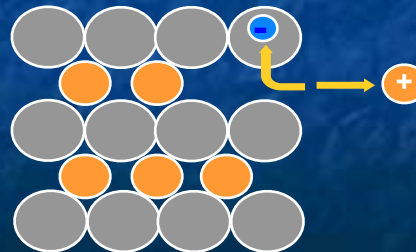

Discharged anode:

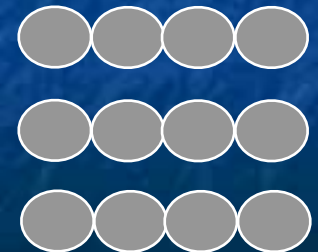

1) <https://www.WeCanFigureThisOut.org/VL/Nanocarbon.htm>

For the Li-absorbing **Cathode**, a common choice is crystalline **LiCoO<sub>2</sub>**:

**CoO<sub>2</sub>** crystals also have layers between which Li can slither

As the cathode of a Li-Ion battery, **LiCoO<sub>2</sub>** can be represented edge on as:

Charged battery:

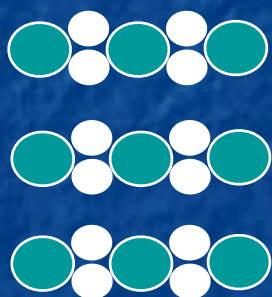

Discharging battery:

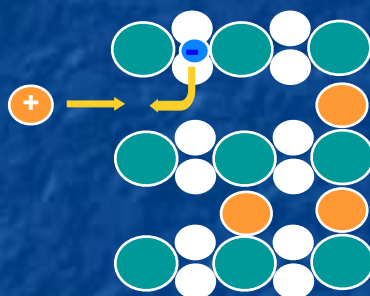

Discharged battery

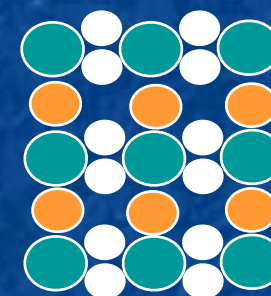

Combining these Anode and Cathode behaviors

produces what is called the **Lithium Cobalt Oxide (LCO) Li-Ion Battery**:

# The LCO Li-Ion Battery structure and behavior:

DISCHARGE transfers **Li** from **inside** the anode to **inside** the cathode:

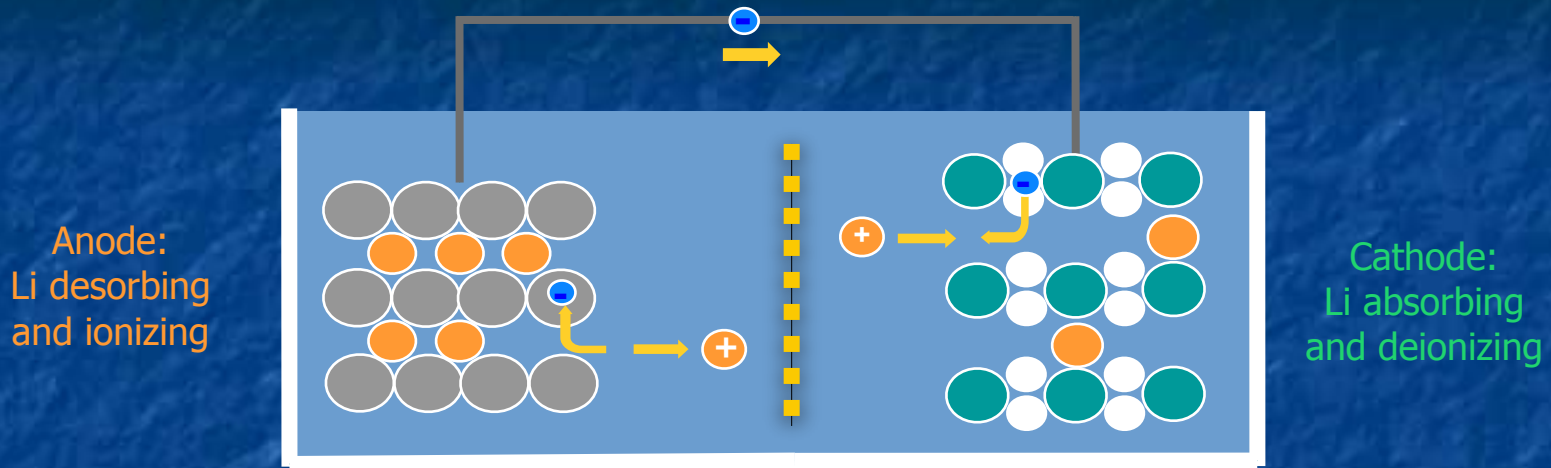

CHARGING transfers **Li** back from **inside** the cathode to **inside** the anode

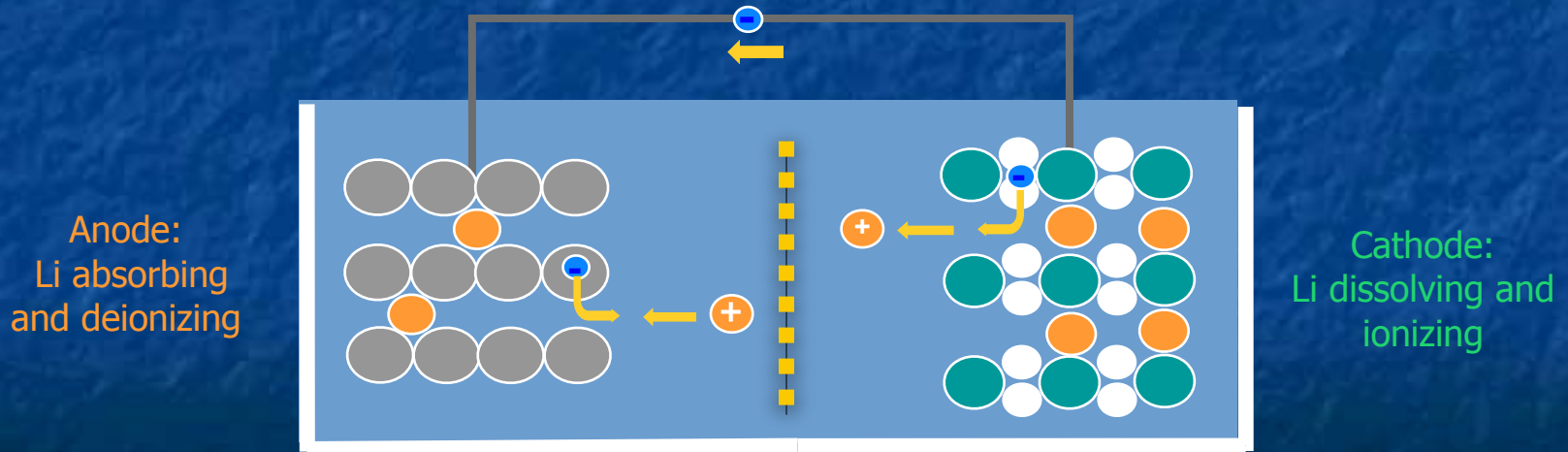

Where ■■■■■■■■■■ is the added anode / cathode **separator**

*But other materials can be used as the cathode:*

Possible replacements for Lithium Cobalt Oxide ( $\text{LiCoO}_2$ ) - **LCO** include:

Lithium Manganese Oxide ( $\text{LiMnO}_2$ ) - **LMO**

Lithium Nickel Manganese Cobalt Oxide ( $\text{LiMnCoO}_2$ ) - **NMC**

Lithium Iron Phosphate ( $\text{LiFePO}_4$ ) - **LFP**

Lithium Nickel Cobalt Aluminum Oxide ( $\text{LiNiCoAlO}_2$ ) - **NCA**

Why bother with so many alternatives?

Because they subtly alter the Li-Ion Battery's characteristics

Which, in turn, changes the applications for which the battery is best suited

Drawing from the exceptionally complete **Battery University** website, <sup>1</sup>

but augmented by data from additional sources, <sup>2-5</sup> here is a comparison table:

- 1) [https://batteryuniversity.com/learn/article/types\\_of\\_lithium\\_ion](https://batteryuniversity.com/learn/article/types_of_lithium_ion)
- 2) [https://en.wikipedia.org/wiki/Comparison\\_of\\_commercial\\_battery\\_types](https://en.wikipedia.org/wiki/Comparison_of_commercial_battery_types)
- 3) <https://iopscience.iop.org/article/10.1088/1757-899X/211/1/012005/pdf>
- 4) <https://iopscience.iop.org/article/10.1088/1757-899X/252/1/012058/pdf>
- 5) <https://www.osti.gov/biblio/1561559>

# Comparison of the most common Li Ion Battery types <sup>1</sup>

<b>Characteristic:</b> <b>Li Ion Battery Type:</b>	Nominal Voltage Output per Cell	Energy Storage Capacity per Mass	Output Current Capacity per Mass	Safety	Hot / Cold Operation	Lifespan	Cost	Typical Applications
<b>Lithium Cobalt Oxide</b> <b>LCO / "Lithium Cobalt"</b> Anode: Graphite Cathode: LiCoO <sub>2</sub>	3.60 V	High	Low	Low	Medium	Low	Medium	Cell Phones Laptops Cameras
<b>Lithium Manganese Oxide</b> <b>LMO / "Lithium Manganese"</b> Anode: Graphite Cathode: LiMn <sub>2</sub> O <sub>4</sub>	3.75 V	Medium	Medium	Medium	Low	Low	Medium	Power Tools, Medical Devices, <b>Electric Vehicles</b>
<b>Lithium Nickel Manganese Cobalt Oxide</b> <b>NMC / "Lithium Nickel"</b> Anode: Graphite Cathode: LiNiMnCoO <sub>2</sub>	3.65 V	High	Medium	Medium	Medium	Medium	Medium	Power Tools, Medical Devices, <b>Electric Vehicles,</b> <b>e-Bikes</b>
<b>Lithium Iron Phosphate</b> <b>LFP / "Lithium Phosphate"</b> Anode: Graphite Cathode: LiFePO <sub>4</sub>	3.25 V	Low	High	High	Medium	High	Medium	Starter Battery (Lead-Acid replacement)
<b>Lithium Nickel Cobalt Aluminum Oxide</b> <b>NCA / "Lithium Aluminum"</b> Anode: Graphite Cathode: LiNiCoAlO <sub>2</sub>	3.60 V	High	Medium	Low	Medium	Medium	Low *	Medical Devices, <b>Electric Vehicles</b> <b>(including Tesla)</b>
<b>Lithium Titanate</b> <b>LTO /</b> Anode: Li <sub>2</sub> TiO <sub>3</sub> Cathode: LiMn <sub>2</sub> O <sub>4</sub> OR LiNiMnCoO <sub>2</sub>	2.40 V	Low	Medium	High	High	High	High *	UPS's, <b>PV Backup,</b> <b>Electric Vehicles</b> <b>(incl. Honda)</b>

[https://wecanfigurethisout.org/ENERGY/Energy\\_home.htm](https://wecanfigurethisout.org/ENERGY/Energy_home.htm)

1) This table was largely constructed from data on: [https://batteryuniversity.com/learn/article/types\\_of\\_lithium\\_ion](https://batteryuniversity.com/learn/article/types_of_lithium_ion)

\* But where that source's text & figures were inconsistent, data from multiple additional sources was also incorporated



*But if you read that table very carefully, you also noticed that:*

**The final Lithium-Ion Battery did NOT use Graphite as its anode**

And its name and acronym did NOT refer to its cathode

Instead, the so-called Lithium Titanate - LTO battery used:

$\text{LiTiO}_4$  as its **anode**

And either  $\text{LiMn}_2\text{O}_4$  or  $\text{LiNiMnCoO}_2$  as its **cathode**

**Is LTO the only Li-Ion battery NOT using Graphite at its anode?**

**No, an alternative is Silicon, which behaves in a very strange way,  
often using non-naturally-occurring / manmade Nanostructures**

Despite being just below C in the periodic table,

Si does not readily form a layered Graphite-like structure

But it does mimic C's other crystalline form, that of Diamond

And in Si's diamond-like form its Si atoms are more widely spaced,

allowing for potentially even greater & faster incorporation of Li atoms

## Comparison of Diamond Carbon and Silicon Crystals:

As depicted in the interactive 3D models elsewhere on this website:

**Diamond Carbon** (0.154 nm long bonds) <sup>1</sup>

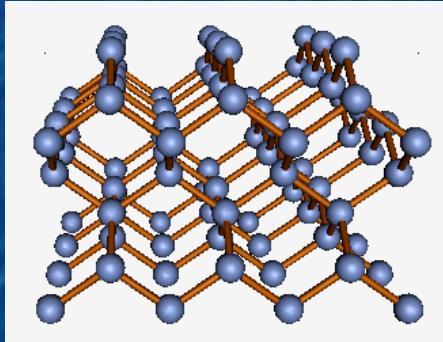

1) <https://www.WeCanFigureThisOut.org/VL/Nanocarbon.htm>

**Silicon** (0.235 nm long bonds) <sup>2</sup>

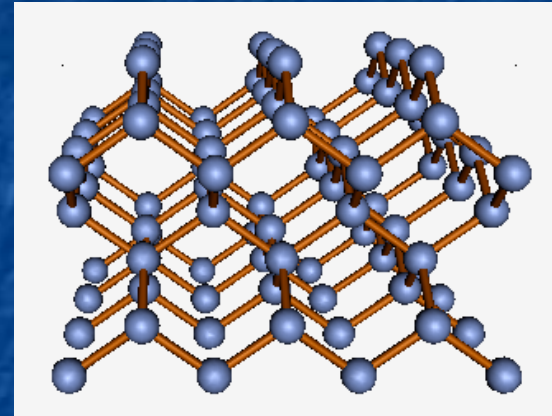

2) [https://www.WeCanFigureThisOut.org/VL/Semiconductor\\_crystals.htm](https://www.WeCanFigureThisOut.org/VL/Semiconductor_crystals.htm)

Due to its long use providing the foundation of the microelectronics industry:

**Silicon crystals of incredible perfection and purity are readily available**

**They come in huge sizes (30 cm dia. x meters long)**

**And can be purchased as precut fully polished wafers for only ten's of dollars**

*i.e., they are almost **begging** to be used as battery electrodes!*

*But there is still a problem (or challenge) for Si anodes:*

To increase Li battery capacity we want to cram huge amounts of Li into the anode

But when that much slithers into its spaces, the **Si crystal actually expands**

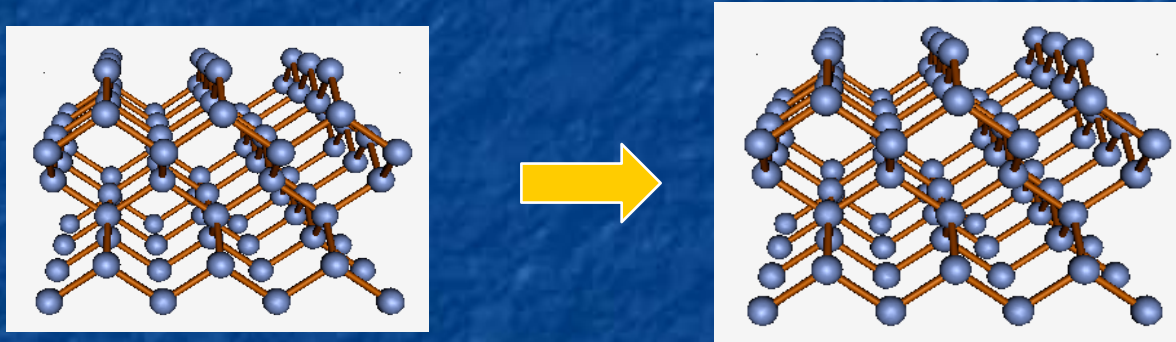

With enough added Li, silicon expands by 2-3 times, actually changing its structure:

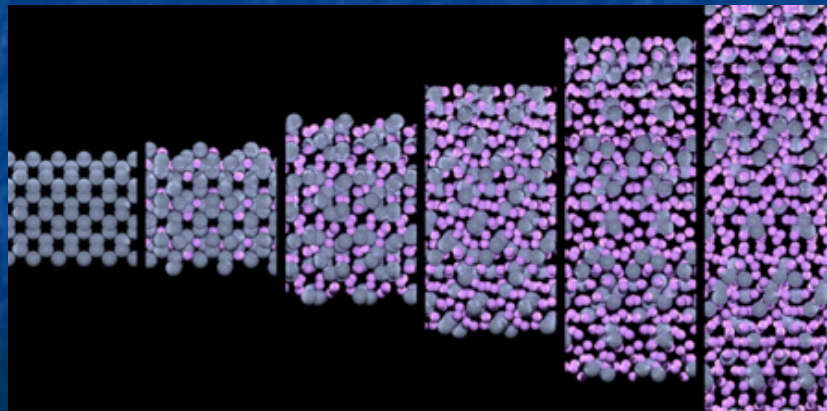

Top from my "Virtual Lab" website: [https://www.WeCanFigureThisOut.org/VL/Semiconductor\\_crystals.htm](https://www.WeCanFigureThisOut.org/VL/Semiconductor_crystals.htm)

Bottom: <http://www.greencarcongress.com/2014/02/20140204-nmr.html>

*But when a Li ion battery discharges, its Si anode must shrink & reorder:*

And, at the very least, we want it to do that a few hundred times

But during **charging** it's likely that Li is not added **uniformly** to the Si

And during **discharging** it's likely that Li is not removed **uniformly**

The resulting non-uniform expansion and contraction of the silicon produces

huge non-uniform stress across the crystal,

leading to the development of cracks and fractures

With these cracks / fractures, as silicon shrinks upon battery discharge:

Si pieces separate meaning that

**electrical contact between those pieces is lost**

Shrinking the anode's effective size & capacity



# *A solution can be provided by forms of **nanoscale self-assembly**:*

For instance: On a Si wafer, create a nanopattern of metal dots,

heat them to melting, and then expose them to  $\text{SiH}_4$  vapor:



$\leq$   $\text{SiH}_4$  vapor approaching one of a vast array of now molten metal dots

The  $\text{SiH}_4$  vapor decomposes, releasing Si to dissolve into the molten metal dot



Si diffuses down to wafer where it solidifies creating a growing column of new Si:



# The result is a tight array of Silicon nanowires:

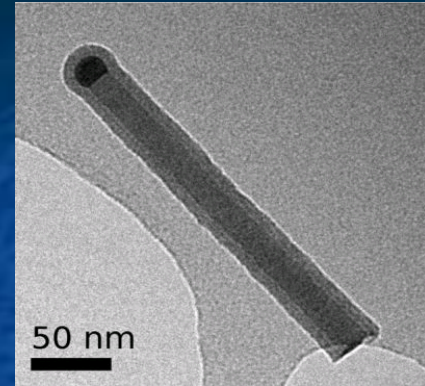
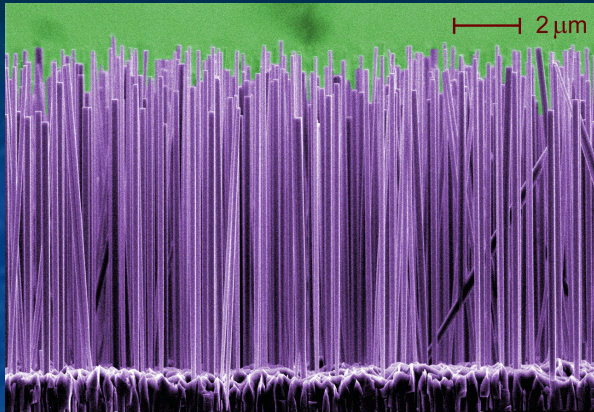

Lorelle Mansfield -NIST:

[http://www.nist.gov/public\\_affairs/techbeat/tb2006\\_0525.htm](http://www.nist.gov/public_affairs/techbeat/tb2006_0525.htm)

U. Helsinki: [www.micronova.fi/units/ntq/research/nanowires.php](http://www.micronova.fi/units/ntq/research/nanowires.php)

Small size / accessibility => Uniform Li absorption & stress, minimal Si cracking:

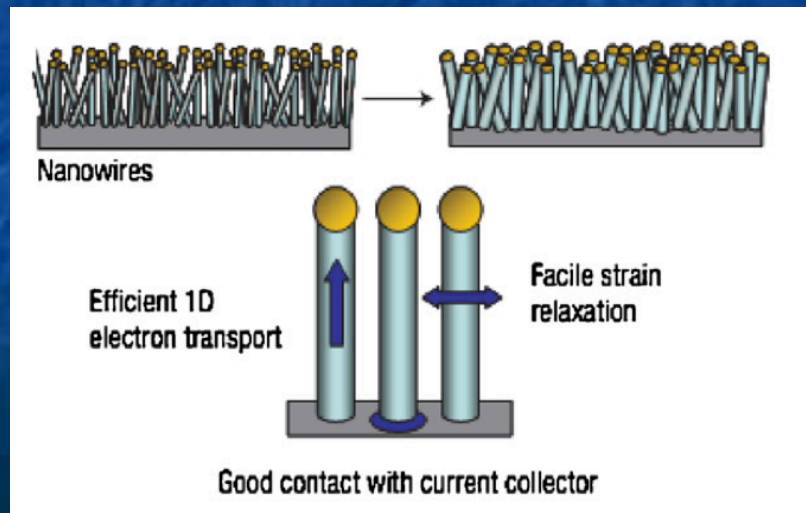

**Nano-structured  
Li ion battery anodes**

## *But before moving on to such futuristic batteries*

There is an important topic I've alluded to but now need to confront head on:

### **Li-Ion Battery Fires**

The YouTube video below illustrates the explosive intensity of such fires ([link](#)) <sup>1</sup>

Li batteries are now credibly linked to at least six major on-aircraft fires <sup>2, 3</sup>

at least two of which progressed into fatal cargo aircraft crashes <sup>4, 5</sup>

And by 2017 the FAA said aircraft Li-battery fires were averaging one every ten days <sup>6</sup>



1) *Functional Macromolecular Laboratory - University of Maryland:*

<https://www.youtube.com/watch?v=HCGtRgBUHX8>

2) [https://www.faa.gov/hazmat/resources/lithium\\_batteries/media/Battery\\_incident\\_chart.pdf](https://www.faa.gov/hazmat/resources/lithium_batteries/media/Battery_incident_chart.pdf)

3) <https://www.consumerreports.org/faa/battery-fire-in-delta-cargo-hold/>

4) <https://www.flyingmag.com/news/ups-747-crash-highlights-lithium-battery-danger/>

5) [https://en.wikipedia.org/wiki/Asiana\\_Airlines\\_Flight\\_991](https://en.wikipedia.org/wiki/Asiana_Airlines_Flight_991)

6) <https://www.consumerreports.org/product-safety/whats-behind-the-increase-in-lithium-ion-battery-fires-on-planes/>

## *All you need is a short-circuit*

In that video, an **external** one was produced by wiring the battery's terminals together

But nature is perfectly capable of producing its own internal short circuits via

dendrites grown while recharging the **solid Li anodes of Li-Metal Batteries**



And adding dendrite-blocking **separator** barriers ( ■■■■■ ) is less than 100% effective

Which is what led to the use of **Li absorbing anodes in Li-Ion Batteries**:

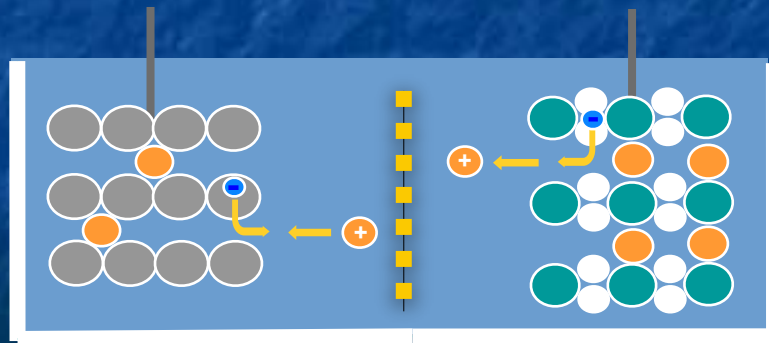

But, under certain conditions, dendrites can **STILL** form on such Li-absorbing anodes



# OK, but why is this a uniquely Li battery problem?

It isn't: Dendrites regularly short out all kinds of batteries

But when that happens (as it has repeatedly in my power tool Ni-Cd batteries),

other types of battery mostly just quietly (if expensively) DIE

Why? Because, when shorted out, they don't release ENOUGH energy

But Li-Ion batteries easily pack an order of magnitude MORE energy

Which, abruptly liberated, IS ENOUGH to start a fire or initiate an explosion

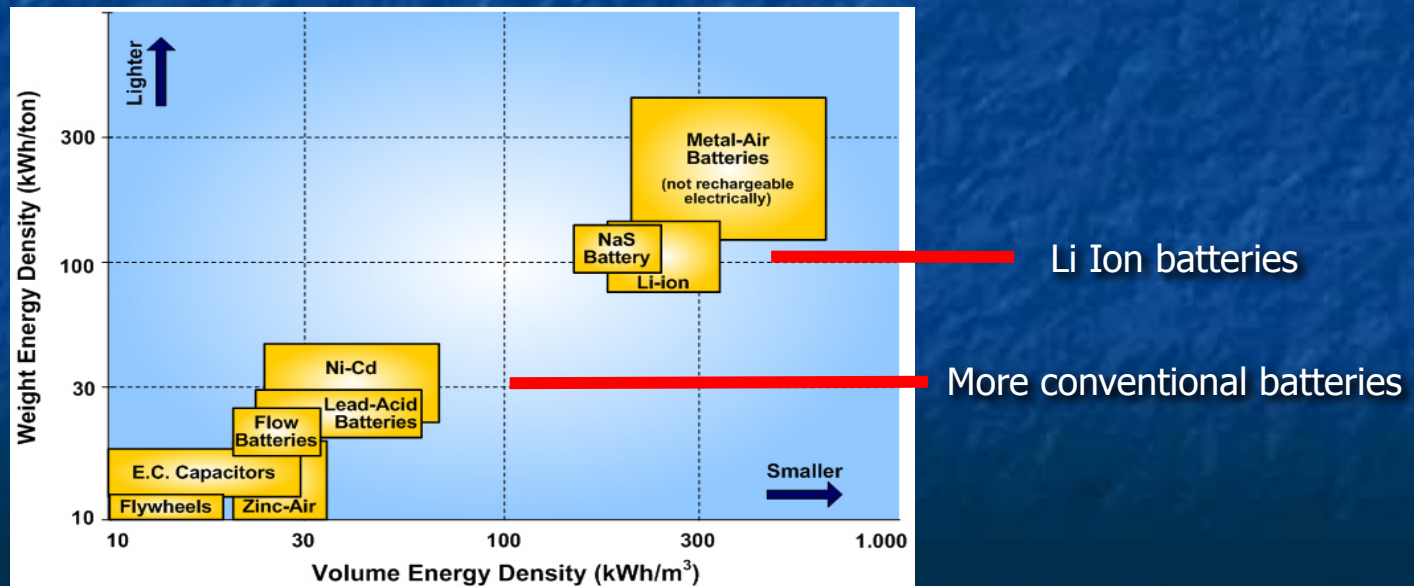

## *So it's more about the **intensity** of failure, rather than the **frequency***

Because, as argued by American Chemical Society, frequency isn't extraordinarily high:

"Failure rates for rechargeable Li-ion batteries are on the order of one in 10 million  
That's not a reliability problem. It's an exception" <sup>1</sup>

But when such an "exception" does occur, it is going to be intense,

intensity increased by Li batteries' necessary use of non-water electrolytes:

"Unlike other common types of batteries, in which the electrolytes consist of aqueous solutions of acid or base, the electrolyte in Li-ion cells typically consists of lithium salts in flammable organic solvents such as ethylene carbonate and ethyl methyl carbonate." <sup>1</sup>

Meaning that what begins as a simple Li oxidation fire

quickly becomes a Li plus electrolyte fire

which may soon be joined by a polymer-based separator fire

meaning that pretty much 100% of the battery will soon be contributing

(at least if the battery has not already blown itself apart)

<sup>1</sup>) <http://cen.acs.org/articles/91/i6/Assessing-Safety-Lithium-Ion-Batteries.html>

# ***Batteries in TOMORROW's homes & ground vehicles***

## *Electric vehicles are now a prime target of battery R&D*

Because **clean power plants serving electrified ground transportation**  
offers one of our best ways of mitigating climate change

At least, if we transition to BOTH clean power plants AND electric vehicles

Because Electric Vehicles (EV's) powered by less than clean power plants  
is just naive way of passing the greenhouse emissions buck

But if we DO soon get our clean power plant act together:

The number of electric ground vehicles x Battery capacity per vehicle = HUGE!

However, EV applications put stellar demands upon batteries - for instance:

We'd like EV batteries charging in the mere **minutes** we now use to fill gas tanks

And with EV's like Tesla's Model S packing **8,256 individual batteries**,<sup>1</sup>

probability of fire per battery better be nothing short of **spectacularly** low

***All of which puts tremendous pressure on the development of:***

1) <https://link.springer.com/article/10.1007/s41918-019-00060-4>

# Tomorrow's Li-Ion Batteries:

For which the search for better Li-storing electrode materials continues unabated

But new R&D also targets four other parts of the Li-Ion battery:

Possibly Li ion-blocking and/or dendrite-nucleating surface layers on the:

**Anode ("Solid Electrode Interfaces" - SEI's)**

**Cathode ("Interfacial Protective Films" - IPF's)\***

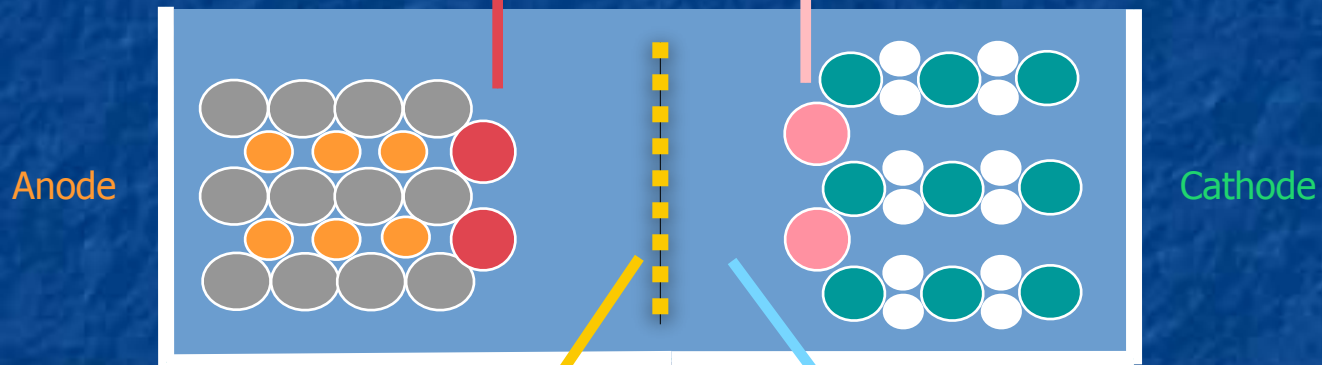

**Better Dendrite-Blocking Separators**

**Dendrite-Blocking Electrolytes**

*\*In some publications <sup>1</sup> these are instead labeled "Cathode Electrode Interface" (CEI) layers*

*1) For instance: <https://link.springer.com/article/10.1007/s41918-019-00060-4>*

# *Li-Ion R&D Parts I & II: Electrode Interface Layers:*

Crystals form when the atoms of a material find particularly low-energy / regularly-ordered ways of binding to one another

In Graphite, energy is minimized when each C atom has three bonding neighbors, with those bonds equally spaced in 2D ( $120^\circ$  apart):

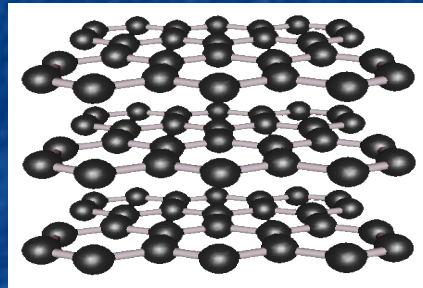

*But atoms at this crystal's EDGES DO NOT HAVE three bonding neighbors!*

In Diamond C & Si, energy is minimized when each atom has four bonding neighbors, with those bonds equally spaced in 3D (about  $109^\circ$  apart):

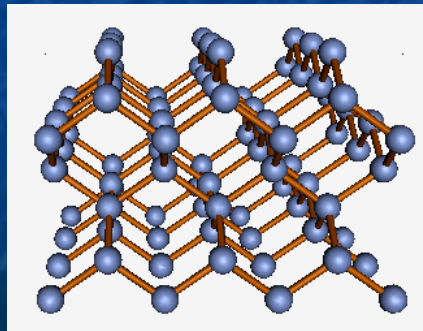

*But atoms at this crystal's EDGES DO NOT HAVE four bonding neighbors!*

**Edge atoms are thus left very "unhappy" (i.e., chemically reactive)**

# *In Li-Ion Batteries, both the Anode and Cathode are crystals:*

And the atoms of their surfaces are thus left similarly unhappy / chemically reactive:



But in the electrolyte's chemical soup, they can find **lots of things to react with!**

Leading to rapid formation of **Surface Electrode Interface (SEI) anode layers**

as well as **Interfacial Protective Film (IPF) cathode layers**

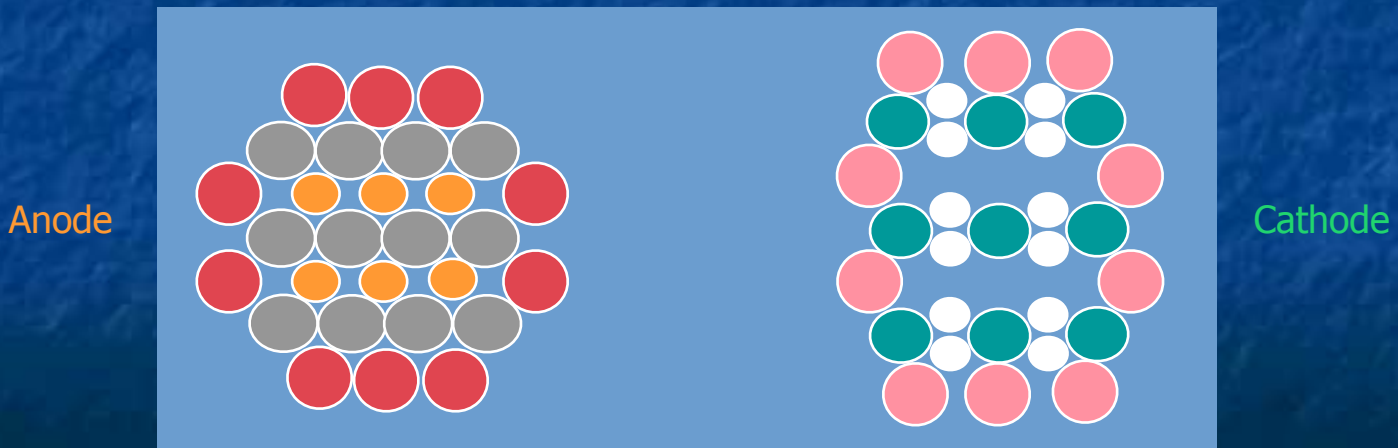

# Which can potentially cripple Li-Ion Battery operation:

DISCHARGING: **Li blocked** from leaving the anode (preventing discharge) and/or absorbing **into** the cathode (driving growth of surface dendrites):

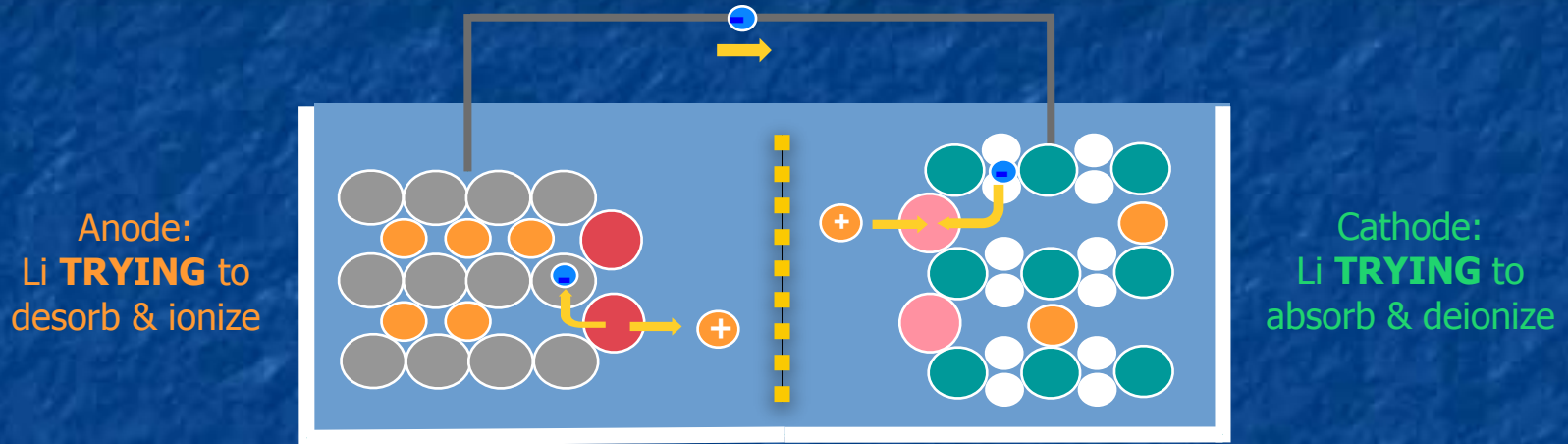

CHARGING: **Li blocked** from leaving the cathode (preventing recharge) and/or absorbing **into** the anode (driving growth of surface dendrites):

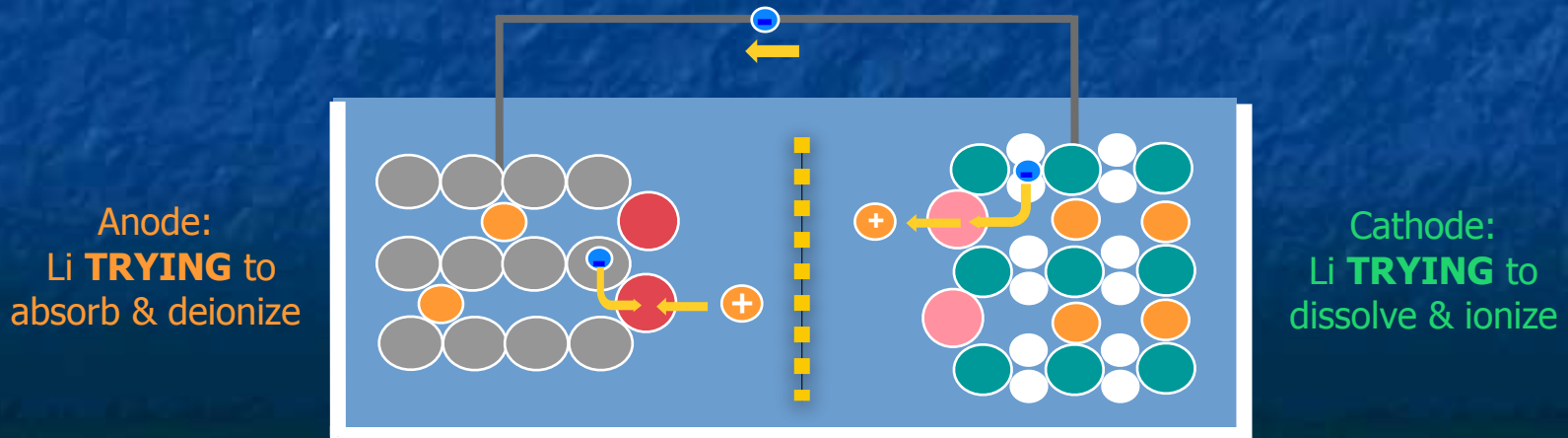



*But controlling those layers is exceptionally difficult:*

**SOME SORT of electrode surface layer is going to form whether you want it or not**

Ideally, it will form from known constituents of the electrode & electrolyte

"Ideally" because that list is short => limited number of layer possibilities

Less ideally, layers will incorporate accidental trace impurities within the battery

Because, at only a few atomic layers thick, those layers don't need many atoms

And nature ALWAYS seeks the lowest possible energy configuration!

Further, the combination that nature DOES settle upon will depend on the exact

mixing & temperature processing sequences used in making the battery,

and upon the battery's earliest charging & discharging procedures

And even if successful fabrication recipes & procedures **are** identified,

**the exact composition & structure of those only few-atom-thick layers**

**is extremely hard to determine - even using the best available analytical tools!**

# *Today's Li-Ion batteries thus require a bit of luck / black magic* <sup>1</sup>

More accurately, they rely upon detailed fabrication & early charging recipes, yielding surface layers that produce batteries with desirable characteristics, even if the exact make up of those all important layers remains unclear

## **A solution:**

### **Limit nature's role by preemptively engineering those critical surface layers**

Many alternatives are being explored, including:

#### **1) Deposited electrode surface coating layers:** <sup>2</sup>

- Which can inhibit undesirable electrode / electrolyte chemical reactions
- Prevent dissolution of electrodes into certain electrolyte solutions
- Trap particularly damaging electrolyte impurities (e.g., HF acid)

Inert metal oxides can provide the desired protection (e.g., TiO<sub>2</sub>, Al<sub>2</sub>O<sub>3</sub>, MgO & ZrO<sub>2</sub>),

but sustained Li<sup>+</sup> flow requires that these layers be **as thin as a single molecule**

1) See: [https://batteryuniversity.com/index.php/learn/article/how\\_to\\_prime\\_batteries](https://batteryuniversity.com/index.php/learn/article/how_to_prime_batteries)

2) See section 4.1.2 of: <https://link.springer.com/article/10.1007/s41918-019-00060-4>

## *Other alternatives:*

### **2) Core-Shell Cathodes** <sup>1</sup>

Which, instead of relying upon applied monolayer scale protective layers, build the cathode as a **thick core** designed to maximize Li storage covered by an **~ 1  $\mu\text{m}$  thick shell** (i.e., ~ 10,000 atomic layers) which serves the protective /  $\text{Li}^+$  ion passing role

But unlike the preceding monolayer scale coatings,

1  $\mu\text{m}$  layers won't necessarily stretch with the underlying material which can lead to cracking or delamination of those thicker layers

### **3) Concentration Gradient Cathodes** <sup>1</sup>

Which try to avoid cracking / delamination by **gradually changing** composition from their Li-storing core outward toward their protective/Li-passing surface

<sup>1</sup>) See section 4.1.2 of: <https://link.springer.com/article/10.1007/s41918-019-00060-4>

# ***Li-Ion R&D Part III: Dendrite-Blocking Electrode Separators*** <sup>1</sup>

Today's separators use polyethylene (PE) or polypropylene (PP) carbon polymers which are fabricated into sheets with convoluted networks of micropores through which a crystalline dendrite should have trouble growing

But aside from being flammable, those polymers melt at only 130 / 170°C meaning that under intense battery operation **pores begin to collapse**, increasing the battery resistance, which further heats the battery, eventually producing catastrophic separator failure

**A counter intuitive separator solution:** A PE / PP layered separator in which heating abruptly - rather than gradually - closes down it's Li-Ion passing pores, cutting off current so quickly that thermal runaway is prevented

Then, the still intact but closed down separator becomes an electrical barrier **which mimics a burned out fuse / tripped electrical breaker**

1) See section 4.3 of: <https://link.springer.com/article/10.1007/s41918-019-00060-4>

*A similar effect has been achieved by adding insulating powders*

For instance, powders of strongly temperature resistant  $\text{Al}_2\text{O}_3$ ,  $\text{TiO}_2$  or  $\text{SiO}_2$ ,

When densely packed within porous PE or PP sheets, as temperature rises

the polymers soften allowing the powder particles to compact together,

forming not only an electrical barrier but a very temperature-resistant one

**Versus the intuitive strategy of just building a temperature resistant separator**

which would not fail, and thus would not require fuse-like failure protection

Thermal stability can be enhanced by use of different (but still flammable) polymers

Candidates include polymers with acronyms of PMIA, PI, PET, PPESK, PVDF <sup>2</sup>

Even more stable AND non-flammable separators might be entirely  $\text{Al}_2\text{O}_3$  &  $\text{SiO}_2$

But those brittle crystalline oxides lack the flexibility of organic polymers

Which might exclude use in more compact but convoluted battery structures

Such as the "Jelly-roll" configuration of Ni-Cd batteries:

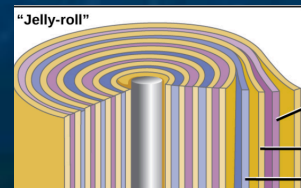

1) See section 4.3 of: <https://link.springer.com/article/10.1007/s41918-019-00060-4>

2) See section 4.3.2 of: <https://link.springer.com/article/10.1007/s41918-019-00060-4>

## Plus one more sort of compromise separator solution:

Retain the flexible if flammable & meltable polyethylene & polypropylene polymers but **"functionalize"** them with by adding chemicals or structures that would **suppress or sharply curtail Li-Ion battery fires**

*In other words: Instead of built-in fuses, build in fire extinguishers*

Below is a scheme encapsulating fire retardant (DMTP) in plastic (PMMA) bubbles, with those bubbles designed to burst open upon battery over-heating: <sup>1</sup>

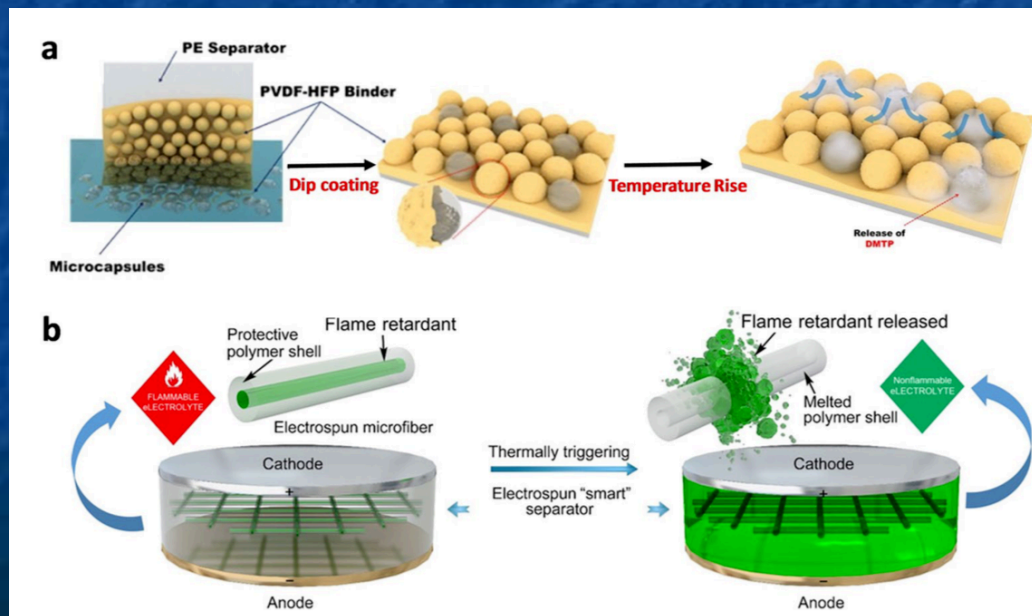

1) See section 4.3.3 of: <https://link.springer.com/article/10.1007/s41918-019-00060-4>

# ***Li-Ion R&D Part IV: Dendrite-Blocking or Inhibiting Electrolytes***

Much of electrolyte R&D targets improved **thermal stability**, <sup>1, 2</sup>

stability of either the electrolyte itself,

or stability of electrode surface layers under exposure to that electrolyte

Or (as with separators) other R&D targets addition of "functional" **fire suppressants**

See, references 1 & 2 for more information on those topics, because . . .

I'm going to jump ahead to an electrolyte R&D thrust I find particularly intriguing:

## **Non-flammable, dendrite-blocking, SOLID state electrolytes**

Which, in essence combines separator & electrolyte into a single robust layer

These solid state electrolytes must retain the ability to easily pass desirable ions

But, like the mostly water-based electrolytes they would replace, they must continue

blocking electron flow (thus forcing electrons out through the battery's terminals)

To do that, solid-state electrolyte materials **must be electronic insulators**

1) See section 4.4 of: <https://link.springer.com/article/10.1007/s41918-019-00060-4>

2) [https://web.stanford.edu/group/cui\\_group/papers/Yayuan\\_Cui\\_NATENG\\_2019.pdf](https://web.stanford.edu/group/cui_group/papers/Yayuan_Cui_NATENG_2019.pdf)

Candidate materials include crystalline structures such as: 1, 2

**PEROVSKITE's** (e.g.,  $\text{Li}_{3x}\text{La}_{(2/3-x)}\text{TiO}_3$ )

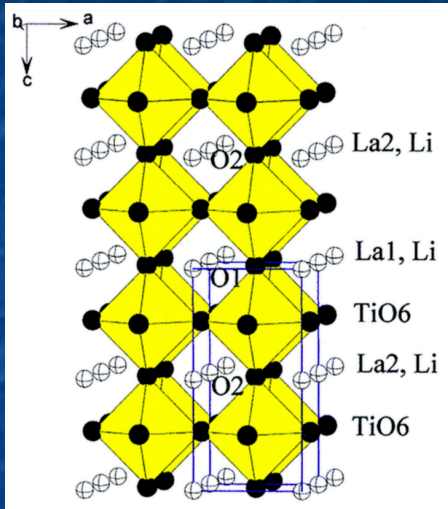

**NASICON's** (e.g.,  $\text{Na}_{1+x}\text{Zr}_2\text{P}_{3-x}\text{Si}_x\text{O}_{12}$ )

**GARNET's** (e.g.,  $\text{Li}_5\text{La}_3\text{M}_2\text{O}_{12}$  w/  $\text{M}=\text{Nb}, \text{Ta}$ )

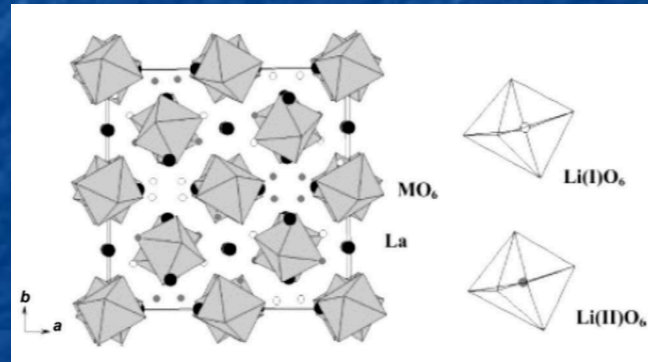

**LISICON's** (e.g.,  $\text{Li}_{4-x}\text{M}_{1-y}\text{M}_y\text{S}_4$  w/  $\text{M}=\text{Si}, \text{Ge}, \text{P}, \text{Al}, \text{Zn}, \text{Ga}$ )

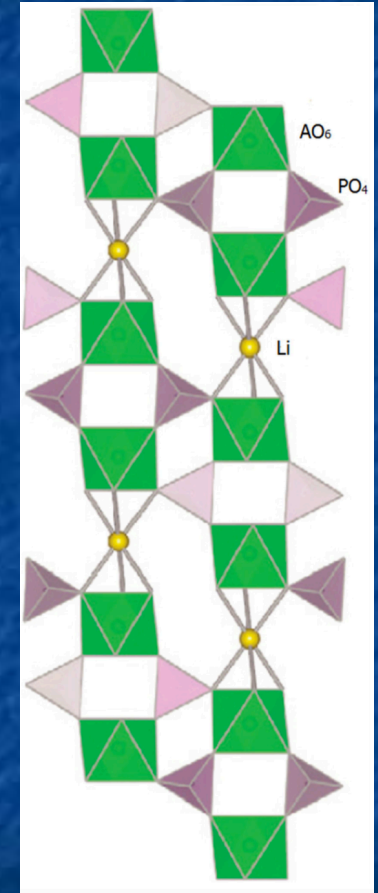
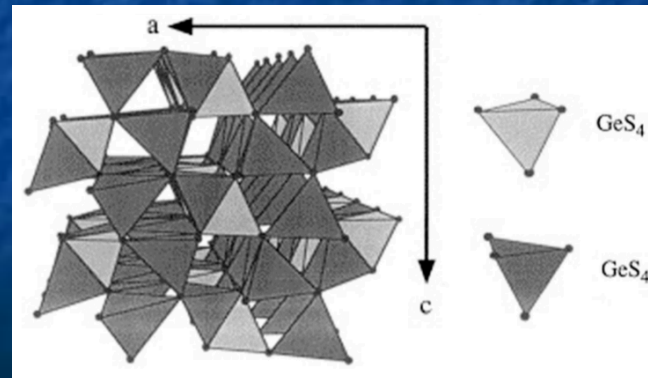

1) <https://www.frontiersin.org/articles/10.3389/fenrg.2014.00025/full>

2) <https://link.springer.com/article/10.1007/s41918-019-00048-0>



## *Challenges confronting Li-Ion battery Solid-State Electrolytes: 1,2*

In these solids, **ions do not flow as easily** as ions in liquid electrolytes

Which increases battery series resistance, lowers current, increases heating

There is also the **difficulty of achieving ion flow into and out of electrodes**

The issue here is that, while liquid electrolytes naturally flow onto the electrodes, thereby assuring atomic-scale contact (and thus facilitating ion flow)

SHEETS of solid electrolyte will NOT automatically bond with electrodes, and a gap of even a few atom widths could easily inhibit and/or block ions

Publications about solid state electrolytes acknowledge these layer contact issues, but they provide little discussion of possible solutions

In fact, these papers give the strong impression that in-battery testing of solid-state electrolytes (**of any type**) is still very, very limited

1) <https://www.frontiersin.org/articles/10.3389/fenrg.2014.00025/full>

2) <https://link.springer.com/article/10.1007/s41918-019-00048-0>

*But the prospect of **solid state electrolyte / separators** seems real:*

Research IS identifying materials with faster internal ion flows

And (ironically) from my note set about **Tomorrow's Solar Cells** ([pptx](#) / [pdf](#) / [key](#)),

I can see a way to producing intimate solid electrolyte to electrode contact:

Poly/microcrystalline layers of **Perovskite** are used successfully in solar cells

That success means micro-crystallites **must** be in intimate electrical contact

In such solar cell layers, contact is achieved by dissolving micro-crystallites into solvents

and then simply **painting them onto surfaces** which,

as the solvent evaporates, brings the micro-crystallites into atomic contact

In fact, with possibly minor degradation in the solid electrolyte's high temperature robustness,

one might even add in a little conductive polymer as a binder,

creating, in essence, something resembling a latex solid electrolyte paint

*I see no **fundamental** reason why such a scheme could not ultimately work <sup>1</sup>*

1) Which I say as one holding a significant number electronic material patents ([link](#))

*But the last dozen plus slides concerned **only** "Tomorrow's Li-Ion battery"*

And viewed critically, they mostly concerned fixes to its safety problems

that would make that technology even more exotic (and thus more expensive)

**Why not take a different path that completely engineers out such problems?**

Producing, for instance, a battery that would not only **not blow itself up**,

but could even be **cooked for 30 minutes over a large gas burner**,

as was demonstrated in this YouTube video ([link](#)) <sup>1, 2</sup>



1) [https://www.bluesky-energy.eu/en/saltwater\\_battery/](https://www.bluesky-energy.eu/en/saltwater_battery/)

2) <https://www.youtube.com/watch?v=HXmZW8Wnvko>

## *That was a so-called **Saltwater Battery***

With that particular one now being marketed as the "Greenrock Saltwater Battery" <sup>1</sup>

Despite, as far as I can tell, using technology directly from Aquion Corp.

which labeled its version an **Aqueous Hybrid Ion Battery (AHI)**

On both the Aquion founder's website,

and in the PBS Nova science documentary **Search for the Super Battery** <sup>3</sup>

Aquion's design goals were given as being:

**A non-portable Grid & Solar Array energy storage battery**

**Using ONLY elements common in earth's crust**

(Which should thus be cheaper and possibly less toxic)

**For which there is NO possibility of fire or explosion**

1) [https://www.bluesky-energy.eu/en/saltwater\\_battery/](https://www.bluesky-energy.eu/en/saltwater_battery/)

2) <https://taspacenergy.co.nz/wp-content/uploads/2015/07/Redwood-Gate-Ranch-Enabling-Solar-and-Reducing-Diesel-Consumption.pdf>

3) [www.pbs.org/wgbh/nova/tech/super-battery.html](http://www.pbs.org/wgbh/nova/tech/super-battery.html)

Which was depicted on **both** Aquion & Greenrock websites as: <sup>1, 2</sup>

**Translation:** Has atomic layers between which ions can slither

**Translation:** Cotton!

**Translation:** Has atomic layers between which ions can slither

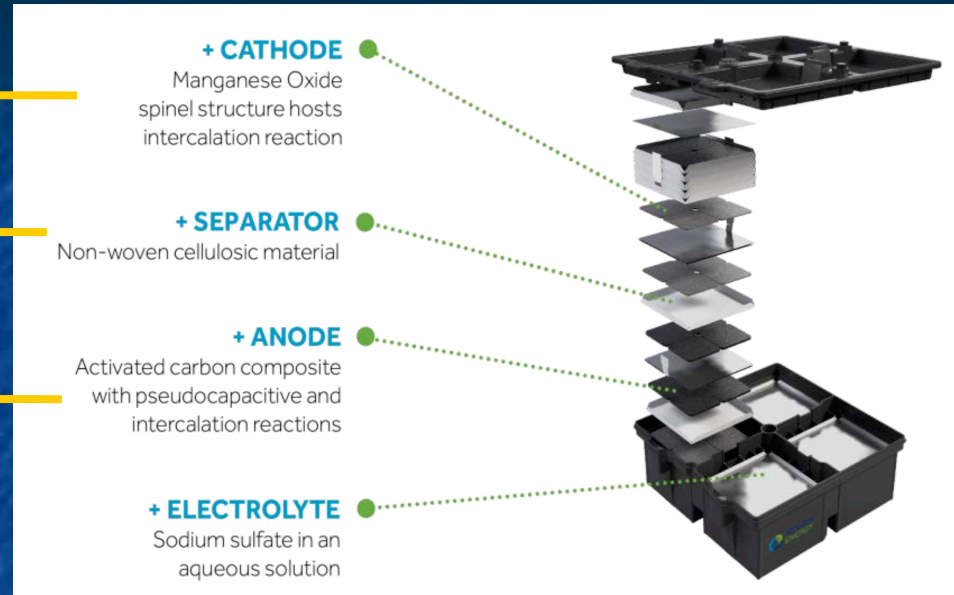

That is: It is based on sodium alkali metal ions (rather than lithium)

It uses an "activated carbon" anode (which is largely graphite-like carbon sheets <sup>3</sup>)

Into which the sodium ions intercalate (i.e., fit between the those sheets)

With a  $\text{MnO}_2$  cathode that also intercalates (i.e. fits sodium ions between its layers)

Between which is a "cellulosic" separator (actually cotton)

And a sodium sulfate water-based electrolyte

2) <https://taspacenergy.co.nz/wp-content/uploads/2015/07/Redwood-Gate-Ranch-Enabling-Solar-and-Reducing-Diesel-Consumption.pdf>

2) 1) [https://www.bluesky-energy.eu/en/saltwater\\_battery/](https://www.bluesky-energy.eu/en/saltwater_battery/)

3) [https://en.wikipedia.org/wiki/Activated\\_carbon](https://en.wikipedia.org/wiki/Activated_carbon)

*Thusly explained, the technology does not sound very exotic*

Indeed, the only big changes seem to be

the use of sodium and a change to conventional water-based electrolyte

Aquion's website does not enumerate the electrochemical reactions involved

Nor explain why Na ions tolerate aqueous electrolytes, while Li ions do not

But on a blog by the company's founder (James Whitacre) I did find this figure

Which does indeed look remarkably conventional:

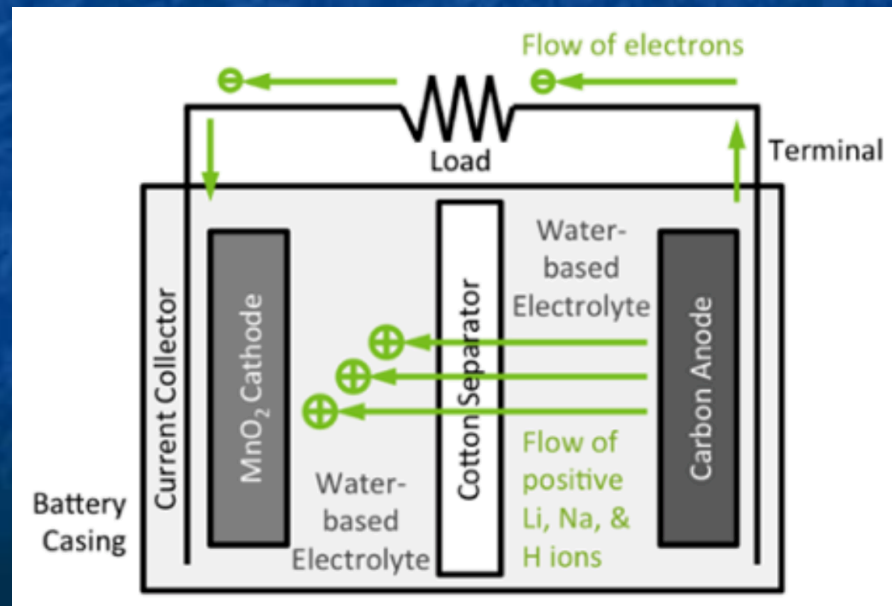

*What's Inside an Aqueous Hybrid Ion Battery?*

<http://blog.aquionenergy.com/blog/bid/108285/what-s-inside-an-aqueous-hybrid-ion-battery-0>

# *An Australian solar energy website supports that interpretation <sup>1</sup>*

Describing the battery as "almost certainly the safest battery around " and that it is:

"about as non-toxic as a battery can get. If you are low on electrolytes I don't recommend drinking it because I don't know the lithium concentration, but if for some reason it leaks you can just mop it up and pour it down the drain. It is likely to cause less environmental harm than one mediocre cow fart.

*(in the PBS documentary, the inventor actually DOES drink the electrolyte)*

It's also noted that the original cotton separator was made from the inventor's shirt

And it mainly finds fault with only the battery's weight and size (per kW-h stored)

Which actually does not contradict the inventor's stated goal

of creating a fixed-position Grid & Solar Array energy storage battery

(applications where weight and size are not super critical)

Meaning that while this battery lacks the versatility & portability of Li-Ion batteries

It is nevertheless a very good candidate for two applications

likely to be essential in the greening of the Grid and home

1) <https://www.solarquotes.com.au/blog/aquion-salt-water-battery/>

## Bringing us to a second rule-changing possibility: **Lithium Air Batteries**

Which, innovative as they are, actually build upon a battery already in widespread use:

The button-style **Zinc Air battery** which powers most of today's **hearing aids** <sup>1, 2</sup>

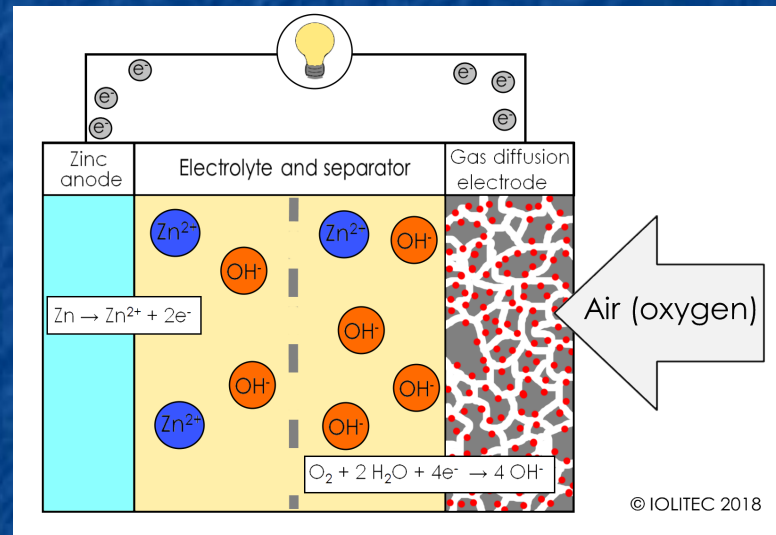

At its anode, Zn is conventionally ionized, releasing electrons:  $Zn (s) \Rightarrow Zn^{+2} + 2e^-$

But air penetrates a uniquely porous cathode, traveling to the electrolyte interface

Where, drawing in electrons,  $O_2$  reacts with water:  $O_2 + 2 H_2O + 4 e^- \Rightarrow 4 OH^-$

Migrating through the electrolyte,  $Zn^{+2}$  and  $OH^-$  then react, forming  $Zn(OH)_4^{-2}$



## Something very similar occurs within a *Lithium Air Battery*

But this more detailed figure highlights the challenge of keeping liquid & air apart <sup>1, 2</sup>

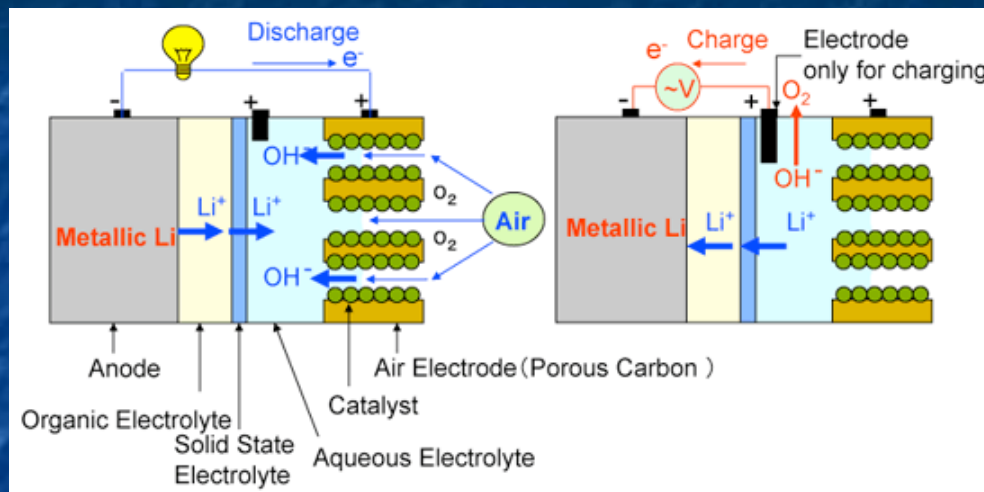

To maintain that separation, a three layer (organic - solid - liquid) electrolyte is used, extending from the anode, rightward into inter-layer gaps within the cathode

In this case it is  $\text{Li}^+$  ions that are liberated by the anode

But these once again meet up with  $\text{OH}^-$  ions liberated from the air / water

reaction now occurring within cathode pores or inter-layer gaps

With  $\text{Li}^+$  and  $\text{OH}^-$  ions sent into the electrolyte reacting to form  $\text{LiO}_2^+$  or  $\text{Li}_2\text{O}_2^+$

## *Advantages of Li Air? 1-3*

Li Air batteries can be **rechargeable** (unlike their present day Zn Air cousins)

Li Air batteries have exceptionally high output voltage based on their pairing of the MOST electropositive element, Lithium,

with the SECOND MOST electronegative element, Oxygen

Because of Li's low mass, and with oxygen coming right out of the air,

Li Air batteries could be exceptionally light

Combined, that should give Li Air batteries outstanding energy storage per mass

And it's thus predicted that they might eventually achieve

**5-10X the stored energy density of today's champion: Li Ion batteries** <sup>1, 3, 4</sup>

Which, for instance, could make them the future's ideal vehicle battery

"Future," because one or more decades of additional R&D are likely required

1) [https://batteryuniversity.com/learn/archive/weird\\_and\\_wonderful\\_batteries](https://batteryuniversity.com/learn/archive/weird_and_wonderful_batteries)

2) [http://www.aist.go.jp/aist\\_e/latest\\_research/2009/20090727/20090727.html](http://www.aist.go.jp/aist_e/latest_research/2009/20090727/20090727.html)

3) [https://en.wikipedia.org/wiki/Lithium-air\\_battery](https://en.wikipedia.org/wiki/Lithium-air_battery)

4) <https://www.extremetech.com/computing/126745-ibm-creates-breathing-high-density-light-weight-lithium-air-battery>

*IBM (of all corporations) is investing in such a possibility: 1*

As seen in their illustration of a would-be 500 mile (800 km) electric vehicle battery:

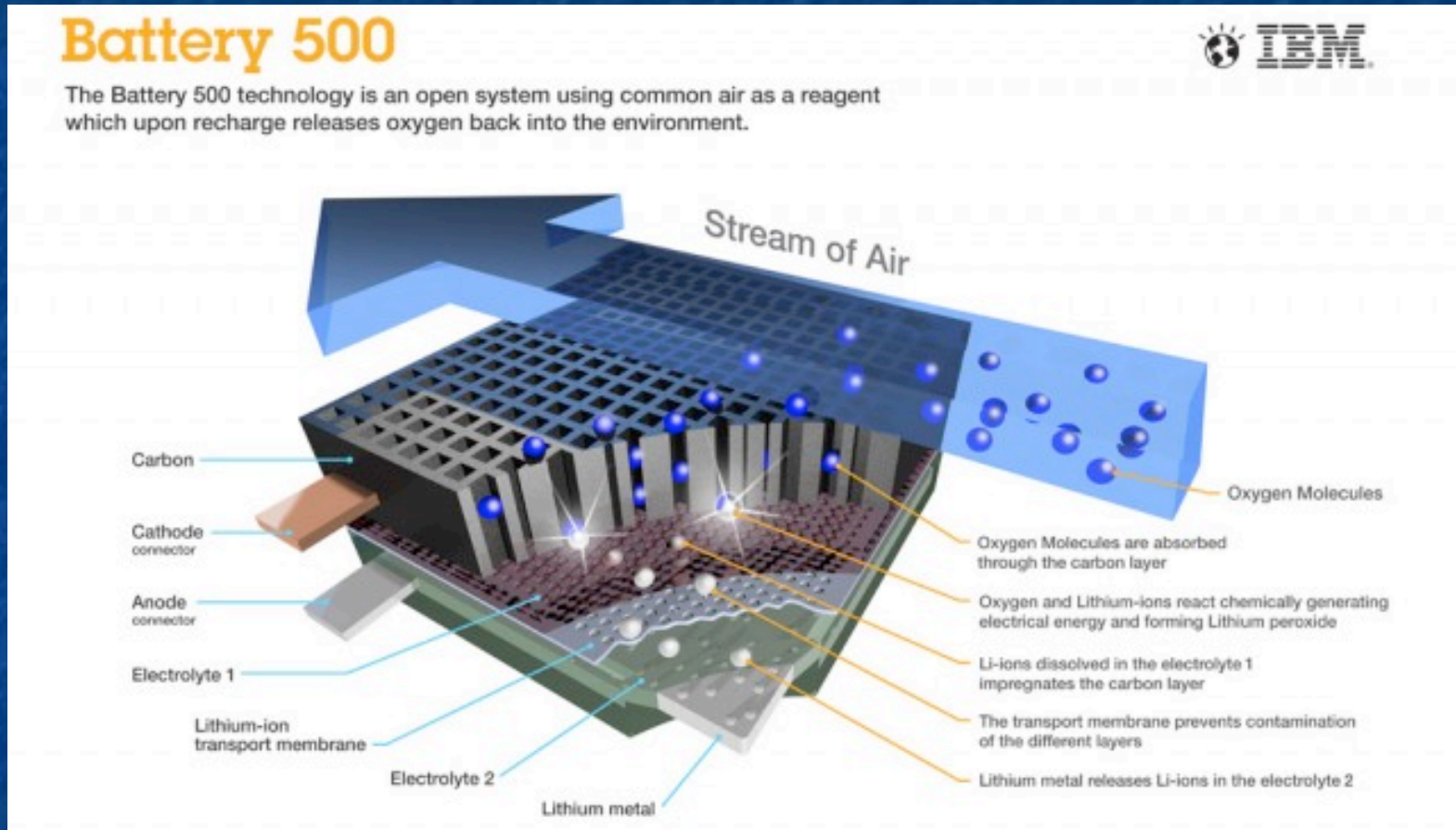

*(Is IBM having a little trouble with their corporate focus?)*

1) <https://www.extremetech.com/computing/126745-ibm-creates-breathing-high-density-light-weight-lithium-air-battery>

***Why practical battery-powered air & sea transport  
is a long way off***

*To this point I have carefully limited my discussion to:*

## Today's and Tomorrow's Home & GROUND Vehicle Batteries

It's time for me to finally explain why I have so carefully dodged the possibilities of

## Battery Powered Airplanes & Battery Powered Ships

It's not because electric planes and ships are a bad idea:

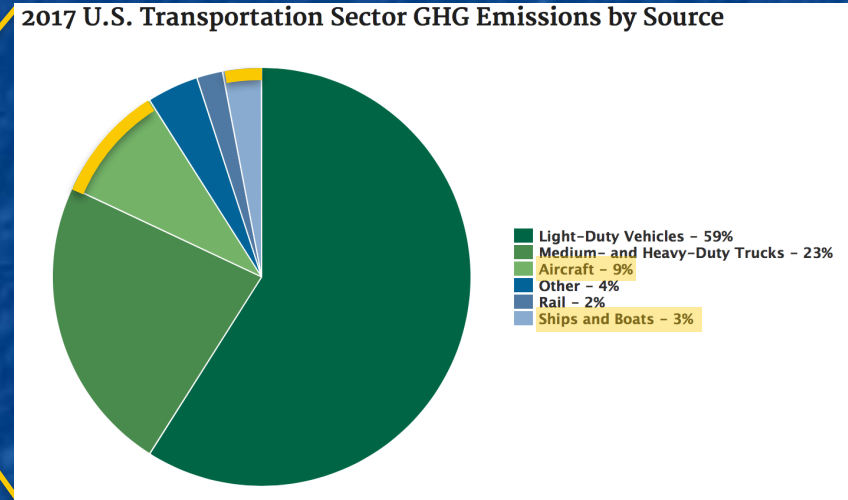
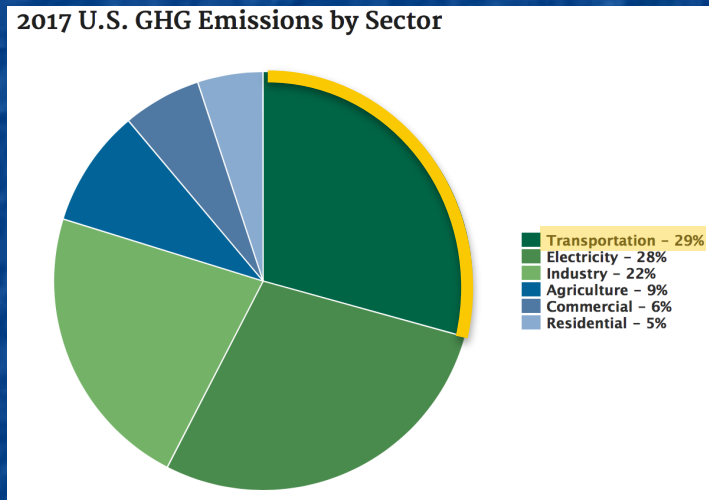

Per the yellow-highlighting I've added to these 2017 EPA charts: <sup>1</sup>

Planes produced  $0.29 \times 0.09 \Rightarrow 2.6\%$  of total U.S. greenhouse gas emissions

While ships produced another  $0.29 \times 0.03 \Rightarrow \sim 1\%$

1) <https://www.epa.gov/greenvehicles/fast-facts-transportation-greenhouse-gas-emissions>

*The problem instead comes from a table spanning several note sets*

A table in which I compared the energy stored per mass, and per volume

for just about every single energy storage technology

discussed anywhere on this WeCanFigureThisOut website

In addition to specific numbers for each technology,

in yellow highlighted columns and rows,

I compared each technology's energy storage to that of gasoline

Which yielded this rather sobering result:

# Energy of various Materials & Storage Technologies: 1

Substance	Specifics:	Energy / Mass			Energy / Volume		
		MJ / kg	kW-h / kg	Ratio to Gasoline	MJ / liter	kW-h / liter	Ratio to Gasoline
Hydrogen Gas (H <sub>2</sub> ) at 20°C	150 Atm. gas *	142	39.4	3.1	1.79	0.50	0.05219
	1 Atm. gas	142	39.4	3.1	0.0119	0.0033	0.00035
Methane Gas at 15°C	150 Atm. gas *	55.6	15.4	1.2	5.67	1.58	0.1658
	1 Atm. Gas	55.6	15.4	1.2	0.0378	0.011	0.0011
Natural Gas at 15°C	150 Atm. gas *	53.6	14.9	1.16	5.46	1.5	0.1596
	1 Atm. gas	53.6	14.9	1.16	0.0364	0.010	0.0011
Propane LPG	Liquid	49.6	13.8	1.1	25.3	7.03	0.74
Diesel Fuel	Liquid	45.6	12.7	1.0	38.6	10.7	1.13
Gasoline	Liquid	46.4	12.9	1.0	34.2	9.5	1
Jet Fuel (Kerosene)	Liquid	43	11.9	0.93	35	9.7	1.02
Fat	Animal or Vegetable	37	10.3	0.80	34	9.4	0.99
Coal	Anthracite or Bituminous	30	8.3	0.65	38	10.6	1.11
Carbohydrates	Including Sugars	17	4.7	0.37			
Ammonia	Liquid	16.9	4.7	0.36	11.5	3.2	0.336
Protein		16.8	4.7	0.36			
Wood		16.2	4.5	0.35	13	3.6	0.380
TNT		4.61	1.3	0.10	6.92	1.9	0.202
Gun Powder		3	0.8	0.065			
Lithium (Mn) Metal Battery		1.01	0.28	0.022	2.09	0.6	0.061
Lithium Ion Battery		0.72	0.20	0.016	3.6	1.00	0.105
Flywheel		0.50	0.14	0.011			
Alkaline Battery		0.59	0.16	0.013	1.43	0.40	0.042
Nickel Metal Hydride Battery		0.40	0.11	0.0086	1.55	0.43	0.045
Lead Acid Battery		0.14	0.039	0.0030	0.36	0.10	0.011
Super Capacitor		0.020	0.006	0.0004	0.050	0.014	0.0015
Capacitor		0.002	0.001	0.00004			

\* Effective Energy / Mass is as much as 100 times smaller for high-pressure gas in heavy tanks

Table source: [https://WeCanFigureThisOut.org/ENERGY/Energy\\_home.htm](https://WeCanFigureThisOut.org/ENERGY/Energy_home.htm)

*Approximating those ratios to gasoline, and highlighting battery results:*

	Energy / Mass	Energy / Volume
Hydrogen gas at 150 Atm. pressure	3	1/20
Gasoline / Diesel / Jet Fuel	1	1
Fat / Coal	3/4	1
Carbohydrates / Protein / Wood	1/3	1/2
High Explosives	1/12	-
Lithium Batteries	1/60	1/12
Flywheels	1/100	-
Conventional Batteries	1/150	1/50
Super Capacitors	1/2000	1/600
Capacitors	1/200000	1/40000

**BIG TAKEAWAY: Fossil Fuels pack 60X to 150X the energy of Batteries!**



## *The impact of such a discrepancy upon **Electric Flight**:*

We think of planes expending most of their energy pushing air out of their way

Which suggests that the key to lower energy flight will be streamlining

But from my note set on **Energy Consumption in Transportation** ([pptx](#) / [pdf](#) / [key](#)):

The energy efficiency of flight is actually best when

**Half of the energy goes into pushing air out of the way**

**Half of the energy goes into pushing air downward**

Air **MUST** be pushed downward to offset the pull of gravity upon the plane

It's just another example of Newton's "Action must equal Reaction"

Heavier planes must thus push proportionally more air downward,

requiring proportionally greater expenditure of energy per mile traveled

**But then, if planes substitute heavy batteries for fossil fuel,**

**they're going to use more energy per distance traveled - But how MUCH more?**

*To answer that, we need to know more about aircraft weight:*

Assume we are talking about medium / large aircraft

carrying passengers and / or cargo,

over distances comparable to medium sized continents or oceans

The forces of physics & economics have driven a convergence of aircraft design

Which is why it's now difficult to tell one transport aircraft from another

A particularly successful / widely used / newer aircraft is Boeing's 777

Wikipedia's webpage on that aircraft included a massive data table

including entries for four different 777 models having different ranges <sup>1</sup>

On the following page I've edited together that table's entries pertaining to weight

For each model I then worked out the percentage of fully loaded aircraft weight

due to the **empty aircraft** itself, its **fossil fuel**, and its cargo/passenger **load**

1) [https://en.wikipedia.org/wiki/Boeing\\_777](https://en.wikipedia.org/wiki/Boeing_777)

# From Wikipedia's data table on the Boeing 777 <sup>1</sup>

Boeing 777 specifications				
Variants	Initial <sup>[184]</sup>		Long-range <sup>[144]</sup>	
Model	777-200/200ER	777-300	777-300ER	777-200LR/777F
Range <sup>[175]</sup>	5,240 nmi / 9,700 km <sup>[d][171]</sup> 200ER: 7,065 nmi / 13,080 km <sup>[e]</sup>	6,030 nmi / 11,165 km <sup>[f][171]</sup>	7,370 nmi / 13,649 km <sup>[g]</sup>	8,555 nmi / 15,843 km <sup>[h]</sup> 777F: 4,970 nmi / 9,200 km <sup>[i]</sup>
Max Takeoff Weight	545,000 lb / 247,200 kg 200ER: 656,000 lb / 297,550 kg	660,000 lb / 299,370 kg	775,000 lb / 351,533 kg	766,000 lb / 347,452 kg 777F: 766,800 lb / 347,815 kg
Empty Weight	299,550 lb / 135,850 kg 200ER: 304,500 lb / 138,100 kg	353,800 lb / 160,530 kg	370,000 lb / 167,829 kg	320,000 lb / 145,150 kg 777F: 318,300 lb / 144,379 kg
Fuel capacity	31,000 US gal / 117,340 L / 207,700 lb / 94,240 kg 200ER/300: 45,220 US gal / 171,171 L / 302,270 lb / 137,460 kg		47,890 US gal / 181,283 L / 320,863 lb / 145,538 kg	

From: Load (People + Cargo weight) = (Max. Takeoff weight) - (Max. Fuel weight), I get:

Range:	10,000 km	11,000 km	13600 km	16,000 km
Aircraft:	138000 kg ~ <b>32%</b>	160500 kg ~ <b>35%</b>	168000 kg ~ <b>32%</b>	144400 kg ~ <b>29%</b>
Fuel:	137500 kg ~ <b>32%</b>	137500 kg ~ <b>30%</b>	145500 kg ~ <b>28%</b>	145500 kg ~ <b>30%</b>
Load:	160000 kg ~ <b>37%</b>	162000 kg ~ <b>35%</b>	206000 kg ~ <b>40%</b>	202000 kg ~ <b>41%</b>

**Aircraft, Fuel, and Load each account for ~ 1/3 of total weight!**

1) With two expanded acronyms, excerpted from main table at: [https://en.wikipedia.org/wiki/Boeing\\_777](https://en.wikipedia.org/wiki/Boeing_777)

## *Those huge fuel loads may surprise you*

But that's how **your carbon footprint from a single long flight can = 1 tonne** <sup>1</sup>

Thus: ( $\sim 250$  passengers per jet)  $\times$  ( $\sim 1$  tonne CO<sub>2</sub> per passenger)  $\Rightarrow$  250,000 kg CO<sub>2</sub>

Confirming that, yes, over a 100,000 kgs of fuel are burned on such a flight!

But the above  $\sim 1/3$   $\sim 1/3$   $\sim 1/3$  aircraft weight distribution rule then implies:

If your aircraft replaced fossil fuels with batteries storing equivalent energy

and they weighed **just 2X as much as the fossil fuel they replaced,**

**you'd have to unload ALL of the plane's cargo & passengers**

which **would** then allow the plane to fly to its destination

even if it did thereby earn ZERO income

**And your airline would set an industry record for going out of business quickly!**

1) For more about personal carbon footprints, see my note set entitled *Where Do We Go From Here?* ([pptx](#) / [pdf](#) / [key](#))

*But that fantasy scenario was based on 2X heavier batteries*

"Fantasy" because from my earlier **Energy Storage Cross Comparison** table:

**Today's experimental Li-Ion batteries are 25X heavier**

**Today's commercial Li-Ion batteries are 75X heavier**

Further, based on their documented tendency to catch fire and explode  
(which is believed to have crashed two cargo planes)

**Li Ion batteries cannot now even be legally shipped on passenger aircraft!**

And looking even farther down my comparison table:

**Acceptably safe & legal batteries are now 150X heavier than fossil fuels**

Meaning that EITHER battery-powered transport aircraft are now totally impractical  
OR that I have made an egregious error somewhere in my calculations

To check on the latter, I dug up a whole bunch of articles about battery-powered flight

## *These articles had widely varying viewpoints & target audiences*

Links to the articles, as well as cached copies

are provided on the [Resource Webpage](#) for this note set

In chronological order, the article titles and sources were:

**Electric Aircraft - The Future of Aviation or Wishful Thinking?** Phys Org, Aug 2015

**The Age of Electric Aviation Is Just 30 Years Away**, Wired, May 2017

**Electric Flight is Coming, but the Batteries Aren't Ready**, The Verge, Aug 2017

**Preparing for Electric Flight**, Royal Aeronautical Society, Aug 2017

**The Long Road to an Electric Airplane Motor**, ZDNet, Sept 2018

**Short Hops, Clear Air and the Sweet Spot for Electric Aircraft**, NewAtlas 2019

In that order, they stated or implied that today's batteries are overweight by a factor of:

43X, 50X, 43X, (?), 14X, 40-48X

Which, sadly, is entirely consistent with my analysis

## *No article predicted near / mid term battery-powered air transports*

The most enthusiastic articles instead dwelt on possible opportunities for small short-hop aircraft and / or

immensely less cost-constrained corporate executive jets

With commercial passenger / cargo aircraft predicted to be ~ 30-50 years in the future, based on their need for revolutionary & thus unpredictable battery breakthroughs

In fact, as described in my note set: **Biomass and Biofuels** ([pptx](#) / [pdf](#) / [key](#)):

**A much more plausible near term path to green aviation is the development of affordable biofuels which, while their burning still releases greenhouse gases, are net carbon neutral over their entire lifecycle <sup>1</sup>**

1) <https://www.greenbiz.com/article/heres-what-it-will-take-get-aviation-biofuels-ground>

# BREAKING NEWS:

## World's Largest All-Electric Aircraft Ready for First Flight The Guardian, 27 May 2020 <sup>1</sup>



***"Can carry nine passengers . . . range of 100 miles"***

Its commercial application is likely feeding rural passengers into main hub airports

But passengers within ~ 50 miles may just drive into the hub airport

Plane's success thus likely depends on transporting passengers from ~50-200 miles out

But to allow for air traffic delays & weather diversions, international regulations

require that aircraft be able to stay airborne for at least an extra 30-45 minutes <sup>2</sup>

To maintain such a reserve, **this plane** might be limited to routes **well under** 100 miles

**Commercial viability thus likely requires at least doubling its range (& passenger load)**

1) [https://www.theguardian.com/world/2020/may/27/worlds-largest-all-electric-aircraft-set-for-first-flight?CMP=Share\\_iOSApp\\_Other](https://www.theguardian.com/world/2020/may/27/worlds-largest-all-electric-aircraft-set-for-first-flight?CMP=Share_iOSApp_Other)

2) <https://aviation.stackexchange.com/questions/3740/what-are-the-icao-fuel-reserve-requirements>



## *Versus the possibility of **Electric Shipping**:*

As noted above, shipping produces ~ 1% of our greenhouse gas emissions

Further, burning many of our rawest grades of fossil fuel,

it produces some of our most health & environmentally damaging emissions

Which has prompted recent calls to curb and / or tax such emissions

Thus, as again cited and linked from this note set's [Resource Webpage](#),

I found a number of articles discussing alternate ways of powering ships

Most such articles focussed on just tweaking today's fossil-fuel engines

But a few articles went on to mention **solar, wind or even nuclear power**

None, however, discussed the possibility of battery-powered ships

**So it's again time to invoke this website's name: WeCanFigureThisOut**

# What do these large modern ships have in common?



Having crammed on top ever more stateroom decks or layers of cargo containers:

**These ships are incredibly top heavy, and to prevent capsizing they NEED low offsetting weight**

Below their waterlines, beneath that income-producing upper deck space:

**Batteries might supply that weight while powering such ships**

But in contrast to aircraft, **you wouldn't need light batteries**, such as Li-Ion's

You'd instead want normal or even exceptionally heavy batteries

**But below those waterlines, is there enough space for enough batteries?**

Left: <https://www.limos4.com/blog/european-cruising-largest-cruise-ships-in-2016>

Right: <http://www.shipspotting.com/gallery/photo.php?lid=2536561>

*To answer that question, we need to figure out two things:*

**The typical below waterline volume of such modern megaships**

**The energy needed to power such ships through the long legs of their voyage**

Despite ship diversity, below waterline volume is often limited by a single consideration:

Retaining the option of someday using the **Panama Canal**



*Figures and data from)  
[https://en.wikipedia.org/  
wiki/Panamax](https://en.wikipedia.org/wiki/Panamax)*

The Canal's older locks accommodate hulls with length x width x draft of:

**290m x 32m x 12m** which defines the so-called **Panamax** class of ship

The Canal's new (2016) locks accommodate hulls with length x width x draft of:

**366m x 51m x 15m**, which is called the **New Panamax or Neopanamax** class <sup>1</sup>

Crudely approximating those below deck spaces as simple rectangular boxes:

**Panamax => 111,360 m<sup>3</sup>**

**Neopanamax => 279,990 m<sup>3</sup>**

## *Next: Energy to move such a ship from China to the U.S. or Europe?*

I found two sources giving the peak power of megaship diesel engines:

An exceptionally large 2004 engine produced up to 110 khp => 86 MW <sup>1</sup>

A broad 2007 study cited container ship engine powers of 22 - 54 MW <sup>2</sup>

Container and cruise ships have since grown very significantly in size,

but during most of their voyage engines may operate at more like 50% power,

so let's estimate a new ship's trip-average power as **~ 50 MW = 50,000 kW**

Which must then be multiplied by the duration of the trip:

Sources give trip length China to US as 20-35 days vs. ~ 30 days to Europe <sup>3, 4</sup>

Using 30 days, energy required = 50,000 kW x 30 x 24 hours = **36,000,000 kW-hr**

From the Energy Storage Cross Comparison table shown a dozen or so slides above:

**Today's BEST experimental batteries store ~ 0.5 kW-h / kg or ~1.2 kW-h / liter**

1) <https://newatlas.com/most-powerful-diesel-engine-in-the-world/3263/>

2) <http://www.dieselduck.info/machine/01%20prime%20movers/2007%20Wartsila%20engines%20for%20panamax%20containerships.pdf>

3) <https://www.chinainportal.com/blog/how-long-does-it-take-to-ship-from-china/>

4) <https://www.theodmgrouop.com/calculating-container-shipping-time/>

*From those data, to provide voyage-long power:*

Such a ship would have to carry: **72,000 tonnes of batteries**

Which would occupy: **30,000 cubic meters**

But you would also need massive shelves on which to secure those batteries

Plus intervening passages and / or overhead space to accommodate  
servicing, cooling, and wiring between those batteries

Suggesting that overall battery space might be more like **60,000 cubic meters**

But looking back at our estimated below-waterline hull volumes:

**Panamax: 111,360 m<sup>3</sup>**

**Neopanamax => 279,990 m<sup>3</sup>**

So this scheme **could work in a Panamax ship, and work easily in a Neopanamax ship**

especially as electric motors are much more compact than diesel engines  
and should thus fit easily in the remaining below-waterline space

**Unlike battery-powered long-distance flight (calculated to now be wildly impractical),  
battery-powered long-distance shipping survives back-of-the-envelope analysis**

## *Then what's holding up electric shipping?*

The most likely answer is, of course, economics

Bloomberg New Energy Finance put 2018 Li-Ion battery cost at \$175 / kW-h <sup>1</sup>

So our hypothetical megaship, requiring a voyage long **36,000,000 kW-hr**,  
might need as much as **6.3 billion dollars in batteries**

(Which might need replacement every 5, 10, 15 years?)

For today's fossil-fueled megaships I found sources giving total construction costs of:

- **105 million dollars** for a 12,000 container-capacity container ship <sup>2</sup>

(today's container ships range up to 23,000 containers)

- Up to **1.5 billion dollars** for cruise ships (e.g., Royal Caribbean's Allure of the Seas) <sup>3</sup>

So it sounds like cost is indeed the problem:

**Battery-powered container ships could cost as much as ~ 60X more to build**

**Battery-powered cruise ships could cost as much as ~ 5X more to build**

1) <https://about.bnef.com/blog/behind-scenes-take-lithium-ion-battery-prices/>

2) [https://en.wikipedia.org/wiki/Container\\_ship](https://en.wikipedia.org/wiki/Container_ship)

3) <https://www.cheatsheet.com/culture/how-much-do-cruise-ships-cost.html/>

## *Which explains why:*

The claimed "World's Largest All Electric Cargo Ship" is this: <sup>1</sup>



Instead of carrying **12-20,000 containers, over 30 days, at 16-25 knots (18-29 mph)** <sup>2</sup>  
this ship, launched by China in 2017, will carry "2,200 tons of cargo"

for a total of "**50 miles** at a top speed of **8 miles per hour**"

**before needing a two hour battery recharge** <sup>2</sup>

From the photo, assuming the total container stack is 4 high x 4 wide x pictured 6 long,  
this ship's full container load looks to be no more than **100 containers**

1) <https://oilprice.com/Alternative-Energy/Renewable-Energy/China-Launches-Worlds-First-All-Electric-Cargo-Ship.html>

2) [https://en.wikipedia.org/wiki/Container\\_ship](https://en.wikipedia.org/wiki/Container_ship)

*I can think of an additional BIG challenge for battery powered ships:*

Economics compels captains to absolutely minimize unproductive time in port

Container ships now unload, reload, and leave port within 24-48 hours

My postulated mega container ship needed **36,000,000 kW-hr** of battery capacity

Which, in port, it would want to recharge within that same 24-48 hours

Assuming that its batteries could cope with such rapid recharging,

it would require incoming electrical power of  $36000 \text{ MW-hr} / (24-48 \text{ hr})$

**= 750 - 1500 MW**

If that harbor served just ten such docked and recharging ships at any point in time:

The total necessary harbor electrical power would be 7.5 - 15 GW,

**REQUIRING AT LEAST 5 TWO-REACTOR NUCLEAR POWER PLANTS**

(or a larger, to hugely larger, number of non-nuclear plants)



## *Why not just add solar roofs to the top layer of containers?*

They could then power the ship & charge batteries during day, with that smaller number of batteries continuing to power the ship overnight

Calculating deck sizes:

Panamax:  $290\text{m} \times 32\text{m} = 9280 \text{ m}^2$

Neopanamax:  $366\text{m} \times 51\text{m} = 18,666 \text{ m}^2$



Drawing on calculations given in my note set: **Today's Solar Cells** ([pptx](#) / [pdf](#) / [key](#)):

Averaged around the clock, for 20% efficient Si PV-solar cells, in different weather:

Output Power =  $25 - 50 \text{ Watts} / \text{m}^2 = 0.025 - 0.05 \text{ kW} / \text{m}^2$

A full deck or container top solar array would thus produce average output power of:

Panamax:  $9280 \text{ m}^2 \times (25-50 \text{ W/m}^2) = \mathbf{232 - 464 \text{ kW}}$

Neopanamax:  $18,666 \text{ m}^2 \times (25-50 \text{ W/m}^2) = \mathbf{464 - 933 \text{ kW}}$

Comparing that to power now used moving such ships (estimated earlier at **50,000 kW**),

**SOLAR PV + BATTERIES => LESS THAN 1/50<sup>th</sup> POWER NEEDED FOR SHIPPING**

# ***Batteries for TOMORROW's greener electrical Grid***

# *That Greener Grid will likely depend heavily upon Solar & Wind power*

But while our need / desire for power peaks in the evening,

Solar power peaks midday:

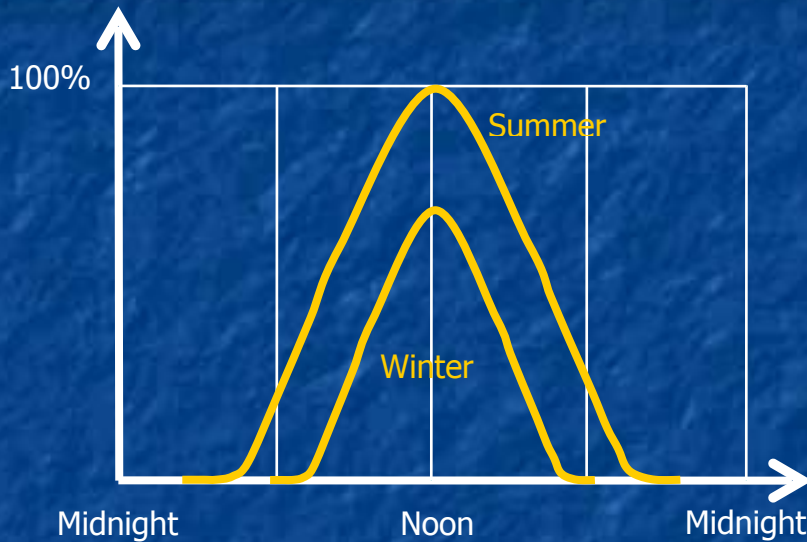

Onshore wind typically peaks late afternoon:

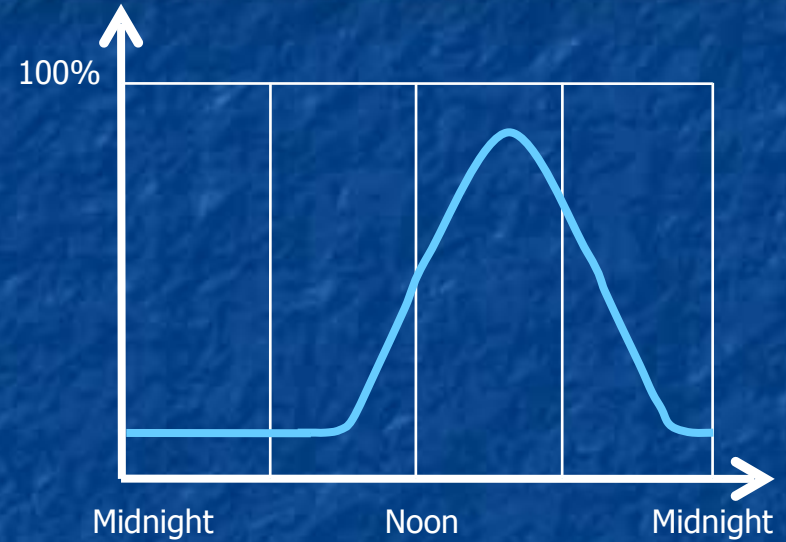

Meaning that evening life with that Greener Grid could end up looking like this:



*The obvious solution is called: **Grid Load Leveling***

Which is the idea of just storing mid / late day power for later evening use

**We have NOT yet implemented Grid Load Leveling to any significant degree**

For details see my notes: **Power Cycles and Energy Storage** ([pptx](#) / [pdf](#) / [key](#))

From that note set: Each day the U.S. now consumes about **11,089 GW-h**

A Green Solar / Wind-based Grid would need to store as much as half  
of that energy during the day, holding it for consumption 6-12 hours later

Batteries are perhaps our best near term bet for providing such storage

But these will have to be very different batteries - batteries that will:

**Store ABSOLUTELY MASSIVE amounts of energy**

**But they'd need to do this for only a very short time**

**And they could be large and massive as they would likely  
just be heaped into HUGE warehouse-like buildings**

## *Batteries now be considered for "Grid load leveling:"*

As cited in a U.S. National Renewable Energy Lab report <sup>1</sup>

- Lead-acid batteries
- Nickel-electrode batteries
- Molten sodium-sulfur modular batteries
- Zinc-bromine batteries
- Vanadium redox batteries
- Polysulfide-bromide flow batteries

Let's examine some of the more aggressive / revolutionary alternatives on that list:

# Ion Flow Batteries:

Which can be represented schematically as: 1

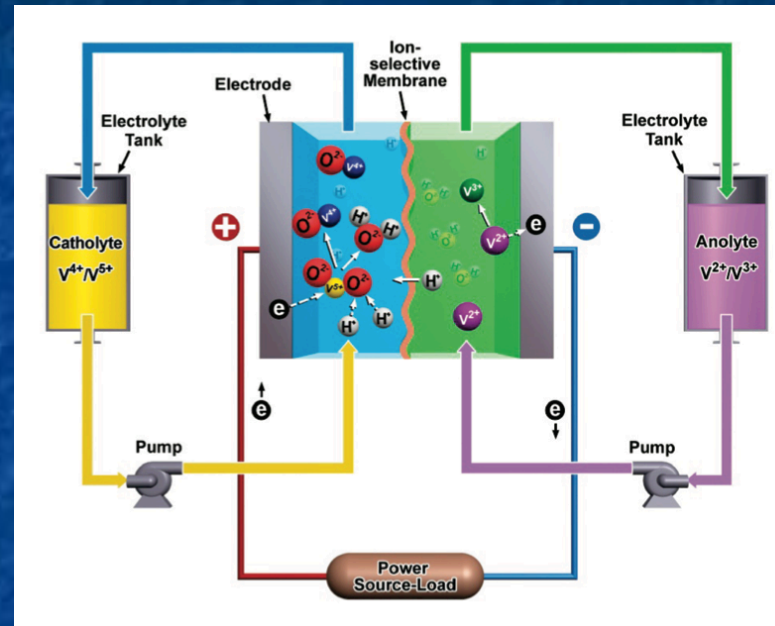

To the left and right are huge storage tanks filled with two different electrolytes

Those electrolytes are pumped into a central cell

containing simple metal electrode plates

between which is an "ion selective membrane" (a.k.a., separator)

1) <https://www.nytimes.com/gwire/2010/10/15/15greenwire-doe-promotes-pumped-hydro-as-option-for-renewable-51805.html>

Figure from: *Electrochemical Energy Storage for Green Grid*, Yang et al., *Chemical Reviews* 111, 3577–3613 (2011)

# Zooming in on the center structure of this vanadium ion version:

## LEFT SIDE:

$\text{VO}_2^{+1}$  ion is pumped in

It reacts with  $\text{H}^+$  ion and **takes electron from electrode**

Becoming  $\text{VO}_2^{+2}$  ion and releasing water

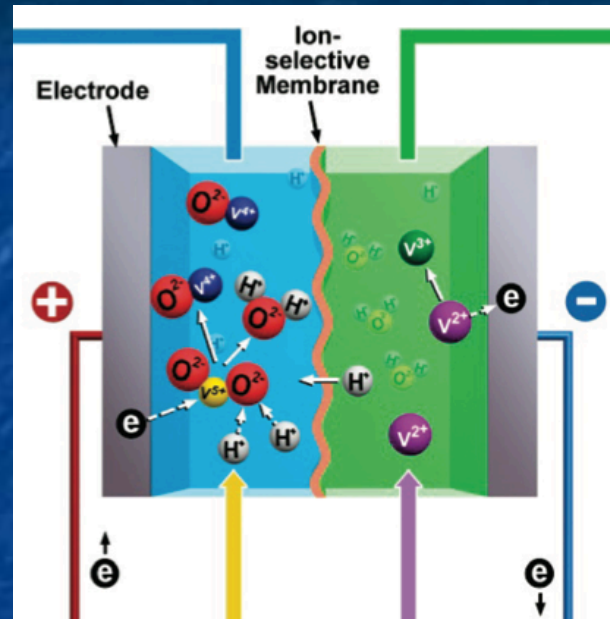

## RIGHT SIDE:

$\text{V}^{+2}$  ion is pumped in

**Giving electron to electrode**

It is converted ion to  $\text{V}^{+3}$

## CENTER:

$\text{H}^+$  consumed on left is replaced by  $\text{H}^+$  **selectively** crossing membrane from right

That is, on left (cathode) side:



And on the right (anode) side:



**Note: These electrodes** are just acting as simple, dumb, inert, slabs of metal

*Then zooming back out:*

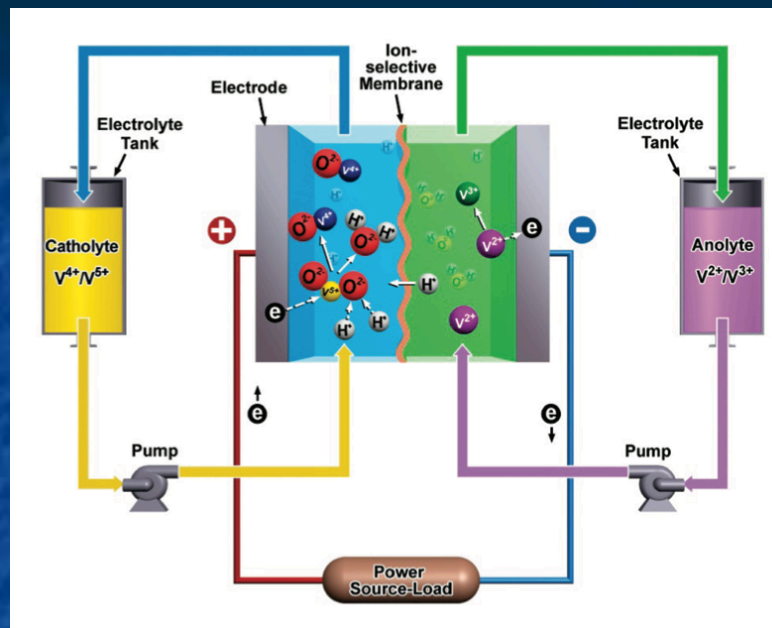

**This Ion Flow Battery is completely discharged only when:**

$VO_2^{+1}$  originally filling left tank is completely replaced by  $VO^{+2}$  leaving cell

$V^{+2}$  originally filling right tank is completely replaced by  $V^{+3}$  leaving cell

**To recharge:** Reverse reactions by forcing electrons FROM left electrode to right

**Editorial comment a la James Clerk Maxwell:**

Tanks MUST ALSO contain charge-balancing negative ions

or electrostatic forces (charge repulsion) would blow them apart!



## *Big advantages of such ion flow batteries:*

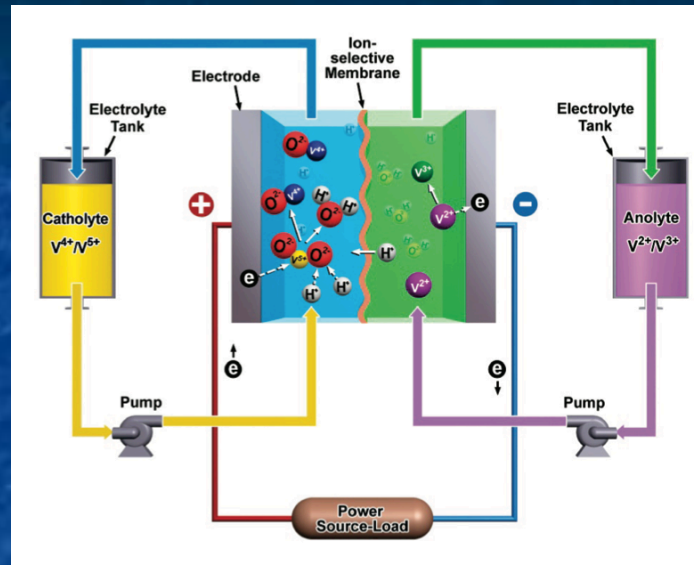

### **1) Battery capacity is NOT determined by cell size**

**Capacity is instead determined by simple external storage tanks**

Which could be gigantic => Gigantic capacity!

### **2) Electrodes are not being rebuilt during recharging**

**Electrodes are instead just static metal plates**

Thus no problem with dendrite short circuits between them!

*This eliminates almost all common electrode problems:*

Including: Limited size, slow surface reactions or diffusion in/out, dendrites . . .

The strategy is to make the solid metal electrodes almost superfluous

Instead transferring almost all of the action to (re-circulating) redox liquids

**Another way of doing this would be sticking with active electrodes**

**But making the electrodes, themselves, liquid**

(Which then easily mix and refresh their redox-able surfaces)

But you must then somehow keep the two electrode liquids from mixing

Because if they did, they'd just swap electrons **locally** (atom to atom)

And we'd again lose electron flow out through wires (= "electricity")

# *This is done in "molten sodium beta alumina" batteries*

## **Their overall structure:**

- Central (anode) reservoir of molten sodium (green)
- Membrane capable of passing Na<sup>+</sup> ions (gray)

Typically: Al<sub>2</sub>O<sub>3</sub> "beta alumina" ceramic

- Surrounding (cathode) outer cylinder (orange)

Typically: Sulfur / Sodium Sulfide (Na<sub>2</sub>S<sub>x</sub>)

In the central anode:



At the outer cathode:

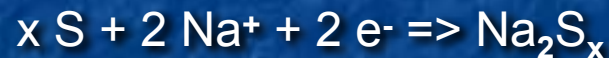

With Na<sup>+</sup> ions formed in anode migrating through beta alumina toward cathode

**These promise for long (50 year+) lifetimes + rapid (high power) discharge <sup>1</sup>**

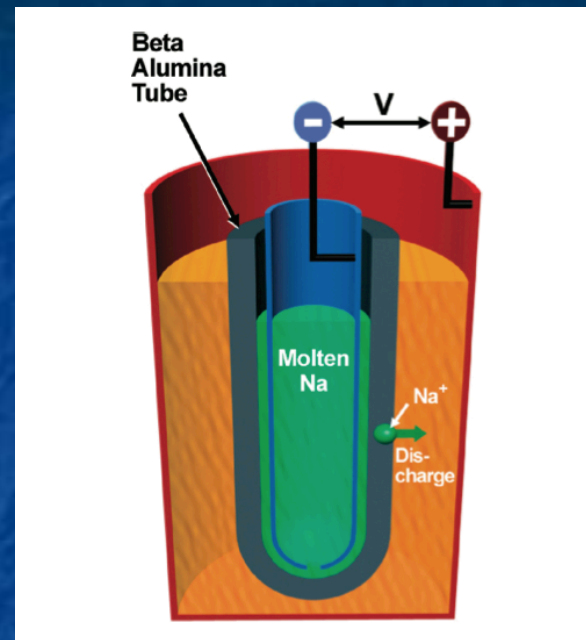

But in recent research **wholly liquid** batteries have been built:

With three liquids chosen for redox properties AND their mass density

Because goal is to have them **naturally segregate** into the three layers of:

Anode / Separating Electrolyte / Cathode

Top: Puddle of lighter liquid lithium  
(floating at stainless steel rod / in Fe-Ni foam)

Middle: Denser molten salt electrolyte

Bottom: Very dense molten antimony-lead

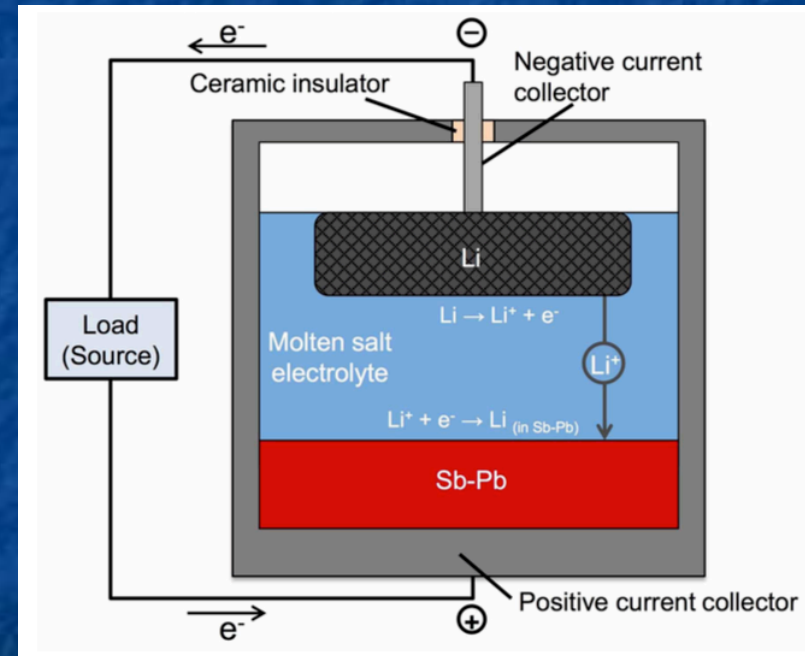

As reported in: Molten metal batteries aimed at the grid, BBC News – Science & the Environment, 21 September 2014  
Based on: Lithium–antimony–lead liquid metal battery for grid-level energy storage, K. Wang et al., Nature 514, p. 348 (2014)

# Battery Operation:

The fully charged battery is described by this figure:

But when a load is connected, it discharges via:

- First, at top liquid to liquid interface (black/blue):



Lithium ions then diffuse down through that (blue) electrolyte layer

- Then, at bottom liquid to liquid interface (blue/red):

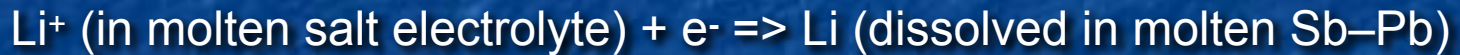

With everything just reversing when the battery is recharged

**Molten metals?** Top: Li metal must be above **180°C**

Middle: 20% LiCl / 50% LiF / 30% LiI must be above **430°C**

Bottom: 18% Pb / 82% Sb must be above **253°C**

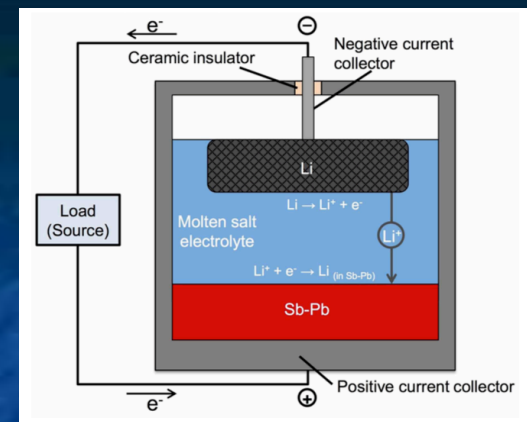

# Comparison of the more established Grid load leveling batteries:

Comprehensive comparative data were **very** hard to find!

**Most** data instead pertained to batteries targeting transportation

This was the most complete data I found (from the University del Pais Vasco, Spain):

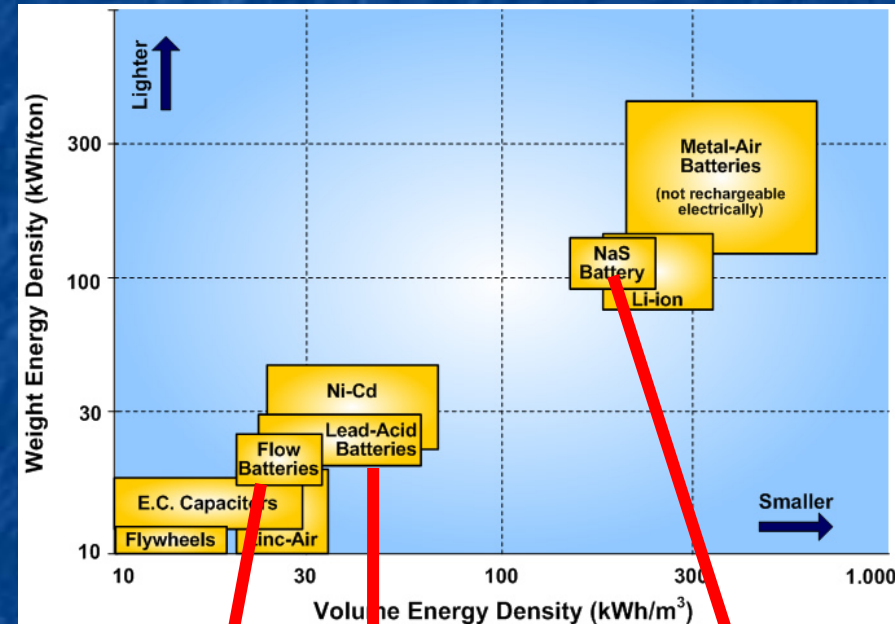
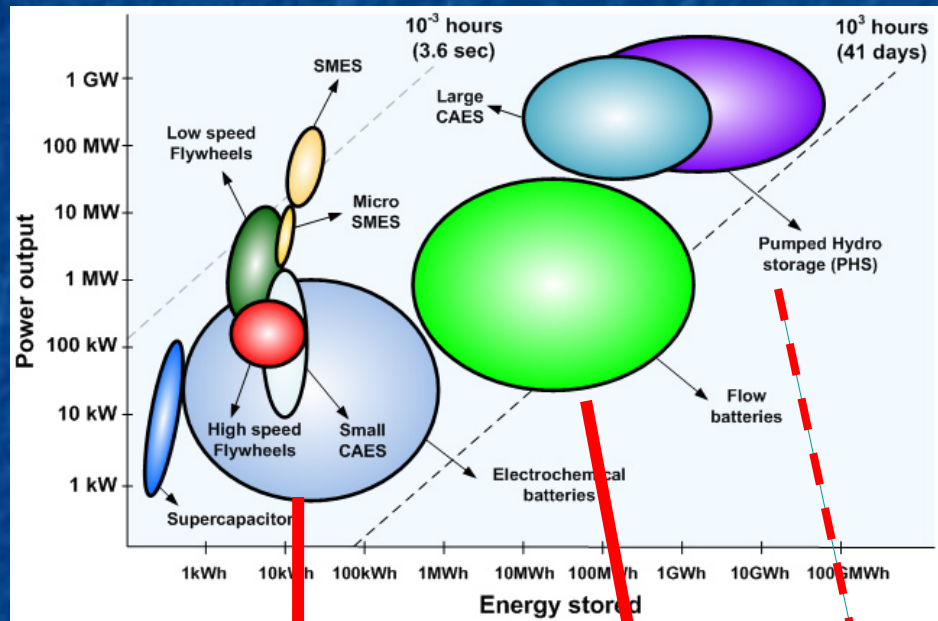

Conventional Batteries

Ion Flow Batteries

Non-battery energy storage alternatives

Ion Flow

Lead Acid

Molten sodium

*Those (and other) batteries target Grid load leveling by:*

Providing potentially **huge** energy storage capacities

Largely via extremely complete and effective use of their redox materials

And, given that redox materials are automatically refreshed by mixing / circulation,

overall battery designs end up being rather simple

All of which should, at least eventually, make cost per energy-stored small

**However:**

**It's very unlikely that 450°C molten-metal batteries will ever go into your car**

**Further, Grid batteries are optimized to charge & discharge on Grid timescales**

Grid timescale = Charging over **many hours** (when energy is **too** available)

= Discharging over the **many hours** of peak evening load

*So let's move onto a final alternative (proposed for both the Grid AND your car):*

# ***Fuel Cells***



## *Batteries AND Fuel Cells call upon "REDOX" ionization / deionization reactions*

But while batteries are typically energized by applied "electricity"

fuel cells are energized by introducing chemicals (fuel),

which are converted to other chemicals, some of which are ultimately exhausted

This fuel in / exhaust out behavior mimics gasoline internal combustion engines (ICEs)

But fuel cells can use carbon-free fuels & exhaust low greenhouse impact gasses

(Although, to be fair, ICEs CAN be reworked to burn hydrogen / emit water)

**Hydrogen Fuel Cells** are featured in most discussions of Sustainable Energy

where they are promoted for BOTH Grid energy storage AND road vehicle power

Hydrogen Fuel Cells will thus be the main focus of the slides that follow

But **Ammonia Fuel Cells** are thought to be more practical for future green ships

I'll touch on the reasoning, but a more complete discussion is provided in my notes:

**Energy Consumption in Transportation** ([pptx](#) / [pdf](#) / [key](#))

Here is the common representation of a Hydrogen Fuel Cell: 1

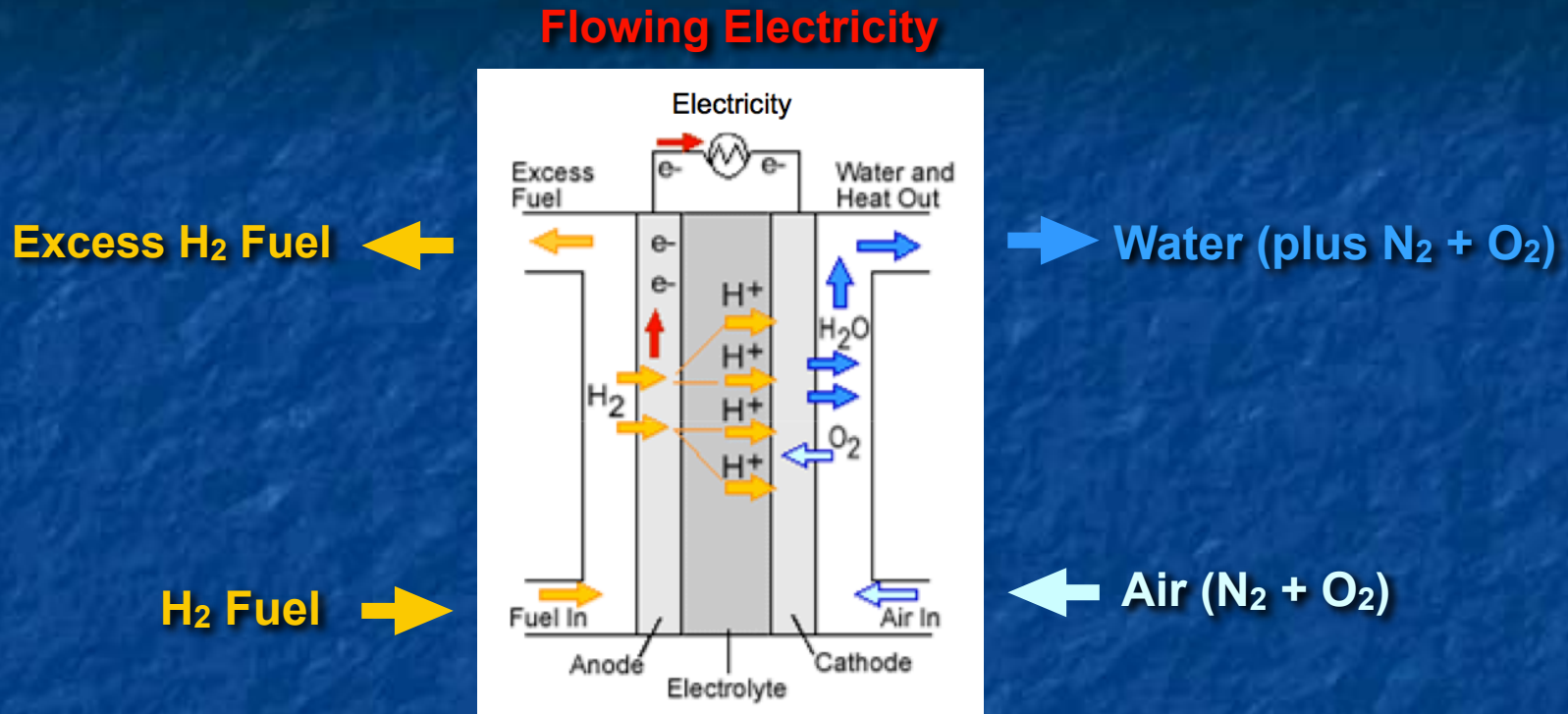

Strictly speaking, this  $H_2$  fuel cell's emitted **water vapor** IS a greenhouse gas

In fact, water vapor is in our atmosphere's **most significant greenhouse gas**

But because oceans & lakes already add so much water vapor to our atmosphere

the likely added contribution due to  $H_2$  fuel cells is usually considered insignificant

*The processes within a H<sub>2</sub> Fuel Cell may be clearer in this schematic:*

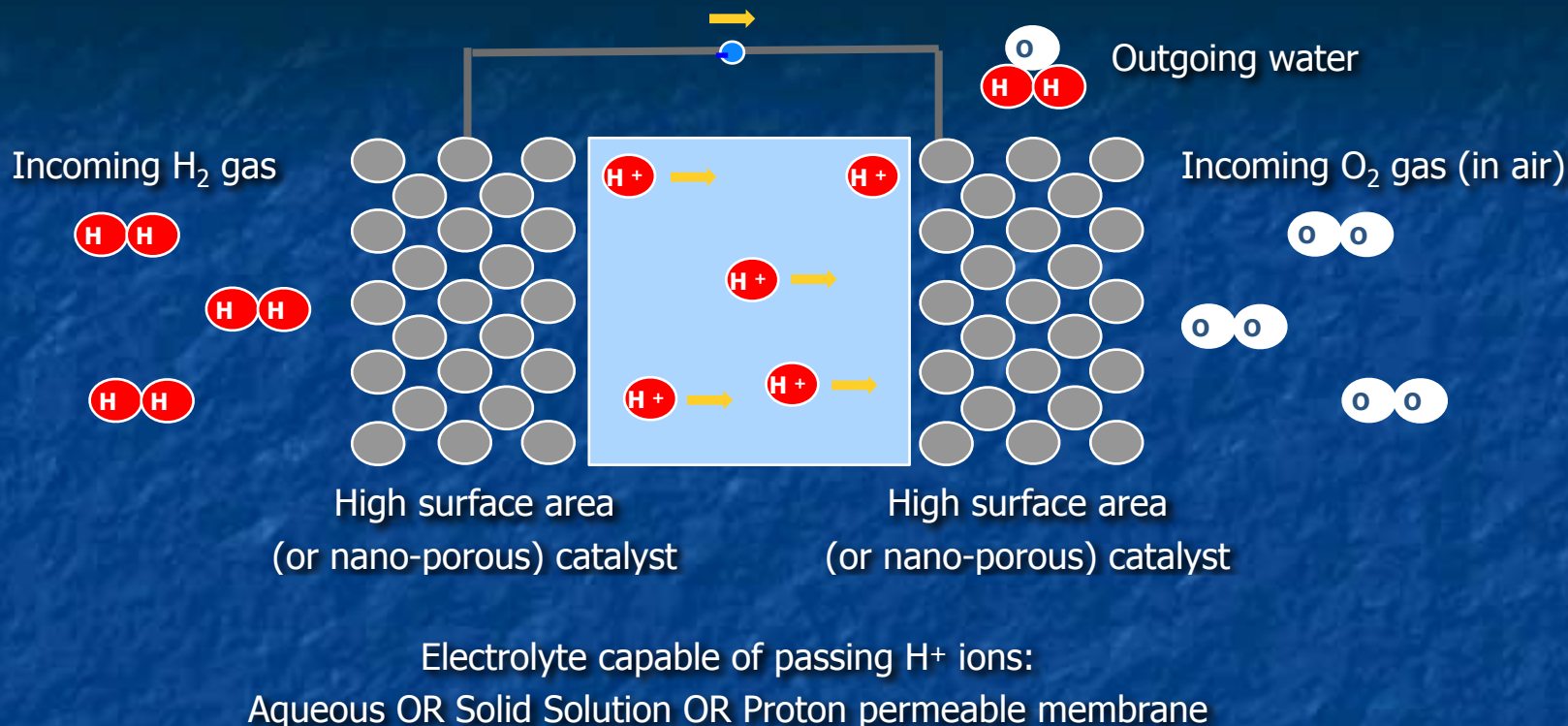

These processes **RESEMBLE** those within **earlier ion flow batteries**:

Where redox species were pumped from external tanks to **inert metal electrodes**

A key **DIFFERENCE**: Gasses don't naturally disassociate / associate on metals

The electrodes above must **catalytically promote disassociation / association**

## *Platinum is the chemists' favorite catalytic fuel cell electrode*

But platinum is a **very expensive** noble metal: **25,172 \$ / kg** (as of 21 April 2020)

Fortunately, catalysis occurs only on surfaces:

And surface area increases when something is ground into a powder

So early fuel cells used electrodes of slightly compacted platinum powder

Hence my reference to use of "porous" metal in the preceding schematic

But for same quantity of Pt, smaller powder particles => **more** total surface area

=> Use of tiny minimally compacted particles (that don't squash back together)

OR, Pt atoms on the surfaces of some other (cheaper) porous nano material

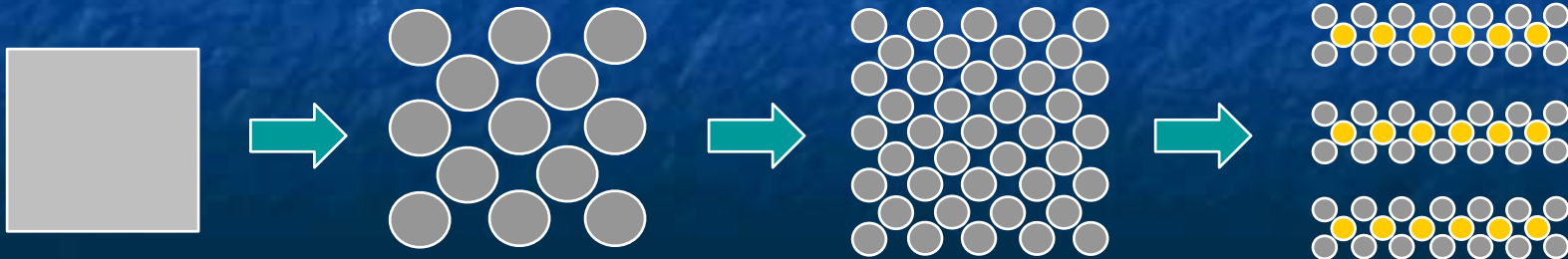

*REDOX reactions are reversible, suggesting H<sub>2</sub> Fuel Cells might be reversible:*

Hydrogen Fuel Cells DO have a process-reversing analog: Water Electrolysis Cells

### Hydrogen Fuel Cell:

Reactions consuming H<sub>2</sub> and O<sub>2</sub> **gases**  
and releasing H<sub>2</sub>O vapor (**gas**)<sup>2, 3</sup>

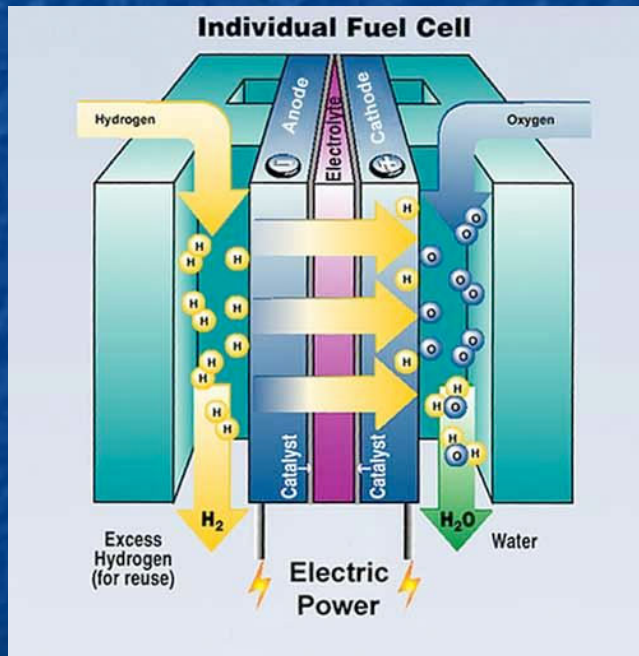

### Water Electrolysis Cell:

Reactions consuming **liquid** water  
and releasing H<sub>2</sub> & O<sub>2</sub> **gases**<sup>1</sup>

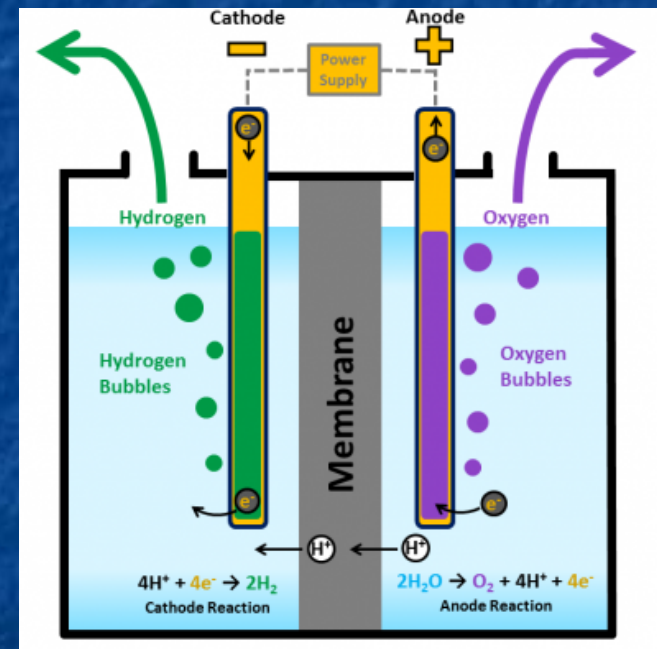

Left figure: <https://www.energy.gov/eere/fuelcells/hydrogen-production-electrolysis>

Right figure: <https://www.betterworldsolutions.eu/more-efficient-production-of-hydrogen-is-possible-says-stanford/>

1) <http://hyperphysics.phy-astr.gsu.edu/hbase/thermo/electrol.html>

2) [https://en.wikipedia.org/wiki/Fuel\\_cell](https://en.wikipedia.org/wiki/Fuel_cell)

3) <https://www.energy.gov/eere/fuelcells/types-fuel-cells>

*For a H<sub>2</sub> Fuel Cell to become reversible, it must be part of a "closed system"*

Where no chemicals are allowed to enter or leave,

and where gases can be transformed into liquids (aided by pumps & compressors)

This yields distinctly **non-simple reversible Hydrogen Fuel Cell SYSTEMS**,

generally based upon either Proton Exchange Membrane (PEM) cells, <sup>1, 2</sup>

or as depicted here, Solid Oxide Cells (SOCs) => "Re(versible) SOC" <sup>3</sup>

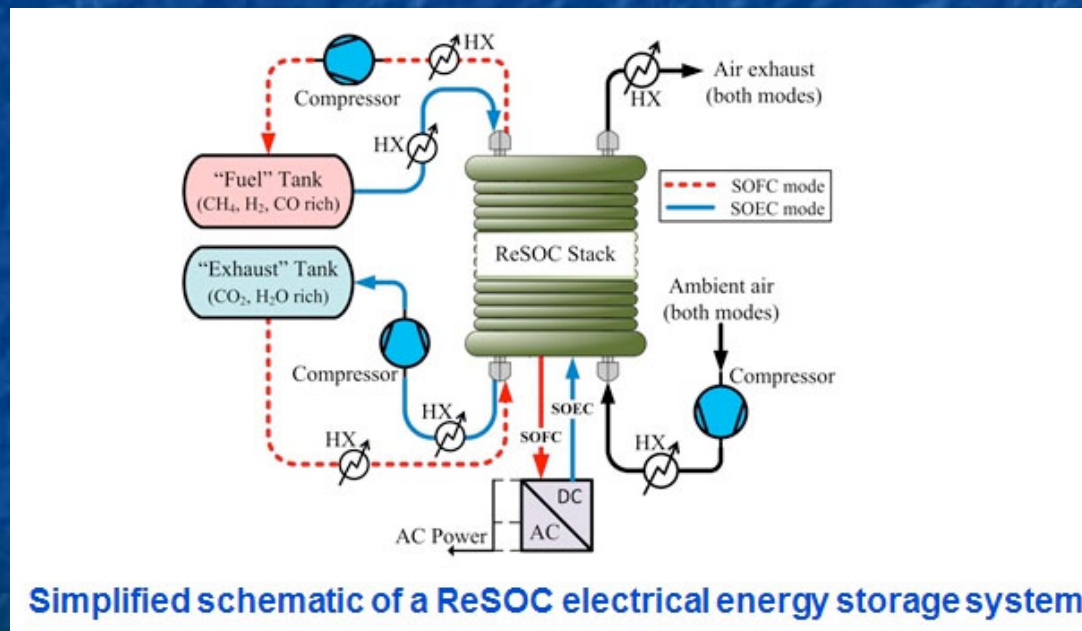

*Figure from: <https://aes.mines.edu/design-and-analysis-of-reversible-solid-oxide-cells-for-electrical-energy-storage/>*

*Imagine how complex the full non-simplified system must be!*

1) [https://en.wikipedia.org/wiki/Regenerative\\_fuel\\_cell](https://en.wikipedia.org/wiki/Regenerative_fuel_cell)

2) <https://www.altenergy.org/renewables/regenerative-fuel-cells.html>

3) [https://www.electrochem.org/dl/interface/wtr/wtr13/wtr13\\_p055\\_062.pdf](https://www.electrochem.org/dl/interface/wtr/wtr13/wtr13_p055_062.pdf)

Further, to operate in both modes, **atomic structures must also be very complex:**

### Solid Oxide Fuel Cell (SOFC) Mode

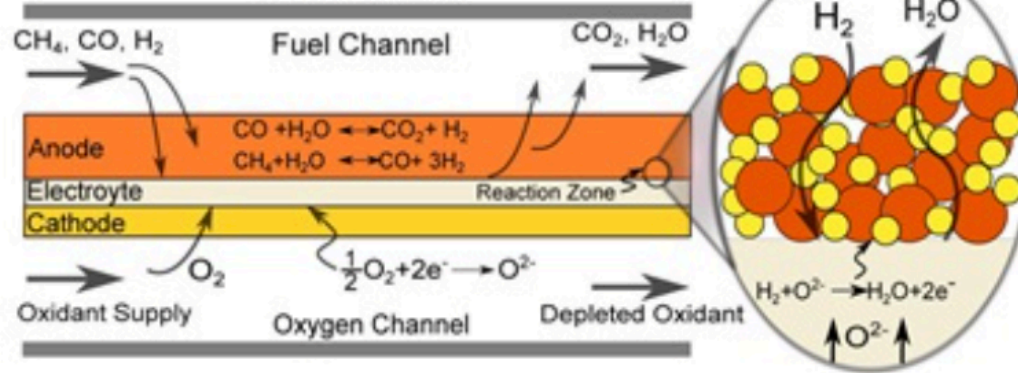

### Solid Oxide Electrolysis Cell (SOEC) Mode

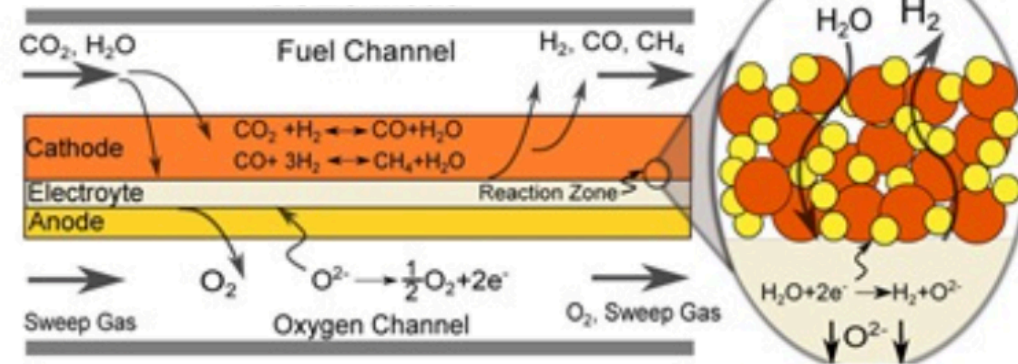

## Reversible solid oxide cell operation

*The above could yield a **Fuel Cell-based Reversible Energy Storage System:***

A compact example was pictured in a U.S. National Renewable Energy Lab report: <sup>1</sup>



Versus a compact example of a **Battery-based Reversible Energy Storage System:** <sup>2</sup>



Such Fuel Cell Storage Systems might, someday, provide critical Grid energy storage

But home use for storage of rooftop solar cell energy seems unlikely

And vehicle use for regenerative braking energy storage exceedingly unlikely

1) <https://www.nrel.gov/docs/fy09osti/44313.pdf>    2) <https://www.dreamstime.com/tesla-battery-lithium-ion-cells-pack-human-hand-st-petersburg-russia-november-close-up-holds-one-cylindrical-logo-image105208002>



*So let's return to simple / non-system / non-reversible H<sub>2</sub> Fuel cells:*

And compare\* simple H<sub>2</sub> fuel cells with simple batteries

as potential compact and green energy sources

to propel our our cars, trucks and possibly even airplanes

\* For a less quick / deeper comparison, see my note sets:

**Energy Consumption in Transportation** ([pptx](#) / [pdf](#) / [key](#))

**Green(er) Cars & Trucks** ([pptx](#) / [pdf](#) / [key](#))

### **H<sub>2</sub> Fuel Cell Pros:**

1) H<sub>2</sub> can be pumped into tanks in mere minutes vs. hours needed to charge batteries

Making quick stop (hydrogen) gas stations possible, while leaving

battery powered cars & trucks charging overnight in garages & parking lots

2) It's claimed hydrogen fuel cells + tanks might be substantially lighter than batteries

Reducing the kinetic energy ( $\frac{1}{2} mv^2$ ) needed to propel fuel cell powered vehicles

# Weight claims are based on hydrogen's energy density per mass

Which was detailed in the left half of my earlier table:

H<sub>2</sub> packs **3 times** the energy per mass as gasoline

and **at least 50 times** the energy per mass as lithium batteries

Substance	Specifics:	Energy / Mass			Energy / Volume		
		MJ / kg	kW-h / kg	Ratio to Gasoline	MJ / liter	kW-h / liter	Ratio to Gasoline
Hydrogen Gas (H <sub>2</sub> ) at 20°C	150 Atm. gas *	142	39.4	3.1	1.79	0.50	0.05219
	1 Atm. gas	142	39.4	3.1	0.0119	0.0033	0.00035
Methane Gas at 15°C	150 Atm. gas *	55.6	15.4	1.2	5.67	1.58	0.1658
	1 Atm. Gas	55.6	15.4	1.2	0.0378	0.011	0.0011
Natural Gas at 15°C	150 Atm. gas *	53.6	14.9	1.16	5.46	1.5	0.1596
	1 Atm. gas	53.6	14.9	1.16	0.0364	0.010	0.0011
Propane LPG	Liquid	49.6	13.8	1.1	25.3	7.03	0.74
Diesel Fuel	Liquid	45.6	12.7	1.0	38.6	10.7	1.13
Gasoline	Liquid	46.4	12.9	1.0	34.2	9.5	1
Jet Fuel (Kerosene)	Liquid	43	11.9	0.93	35	9.7	1.02
Fat	Animal or Vegetable	37	10.3	0.80	34	9.4	0.99
Coal	Anthracite or Bituminous	30	8.3	0.65	38	10.6	1.11
Carbohydrates	Including Sugars	17	4.7	0.37			
Ammonia	Liquid	16.9	4.7	0.36	11.5	3.2	0.336
Protein		16.8	4.7	0.36			
Wood		16.2	4.5	0.35	13	3.6	0.380
TNT		4.61	1.3	0.10	6.92	1.9	0.202
Gun Powder		3	0.8	0.065			
Lithium (Mn) Metal Battery		1.01	0.28	0.022	2.09	0.6	0.061
Lithium Ion Battery		0.72	0.20	0.016	3.6	1.00	0.105
Flywheel		0.50	0.14	0.011			
Alkaline Battery		0.59	0.16	0.013	1.43	0.40	0.042
Nickel Metal Hydride Battery		0.40	0.11	0.0086	1.55	0.43	0.045
Lead Acid Battery		0.14	0.039	0.0030	0.36	0.10	0.011
Super Capacitor		0.020	0.006	0.0004	0.050	0.014	0.0015
Capacitor		0.002	0.001	0.00004			

\* Effective Energy / Mass is as much as 100 times smaller for high-pressure gas in heavy tanks

Table source: [https://WeCanFigureThisOut.org/ENERGY/Energy\\_home.htm](https://WeCanFigureThisOut.org/ENERGY/Energy_home.htm)

# But how much mass must be ADDED TO CONTAIN such hydrogen?

On this question I found remarkably little discussion (much less data)

An exception was two webpages about possible H<sub>2</sub> storage technologies from the

U.S. Department of Energy's Office of Energy Efficiency & Renewable Energy <sup>1, 2</sup>

Their alternatives:

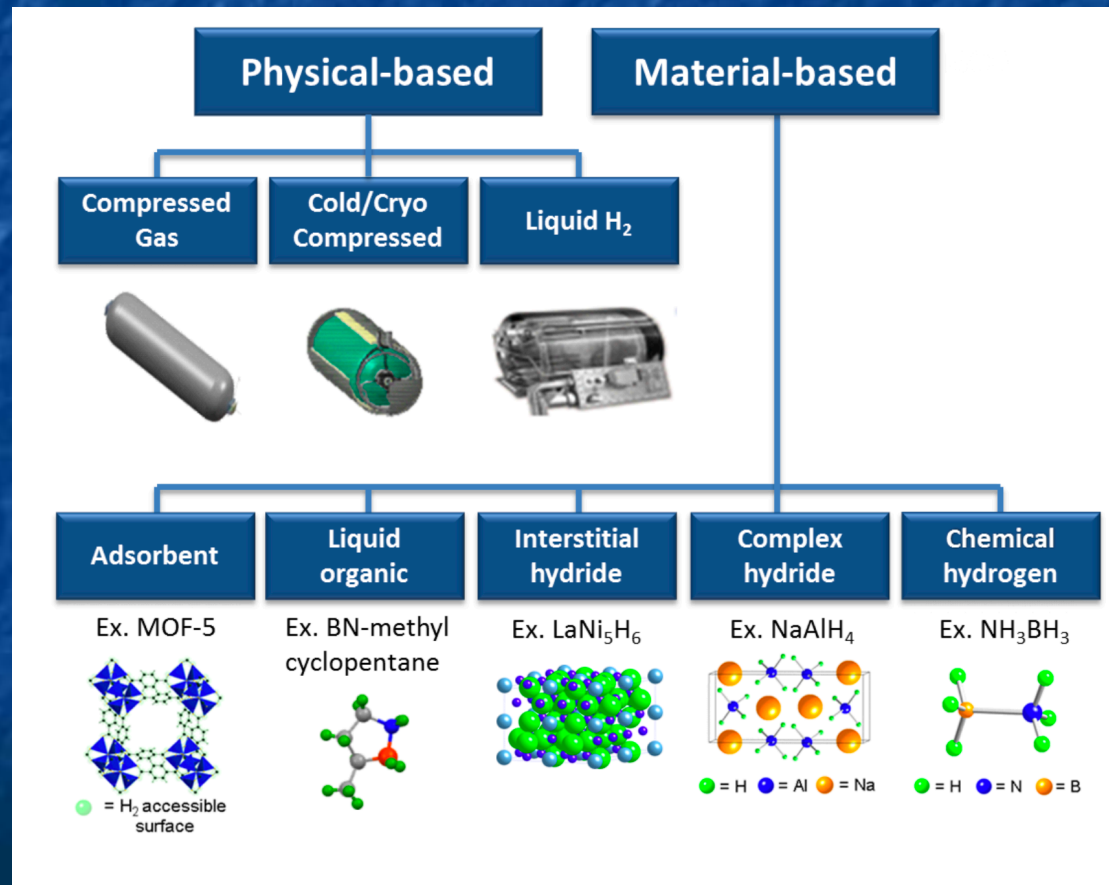

1) <https://www.energy.gov/eere/fuelcells/physical-hydrogen-storage>

2) <https://www.energy.gov/eere/fuelcells/hydrogen-storage>

# Those "Physical-based" $H_2$ storage require massive tanks / systems

To withstand the liquifying pressures and/or provide the necessary hyper-refrigeration: <sup>1</sup>

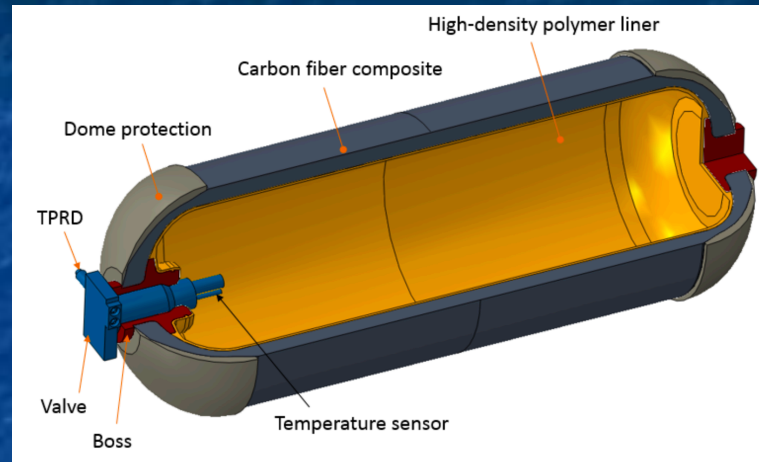

The alternative is lighter but exotic / yet to be fully developed materials, into which large quantities of  $H_2$  might temporarily slither and/or bond: <sup>2</sup>

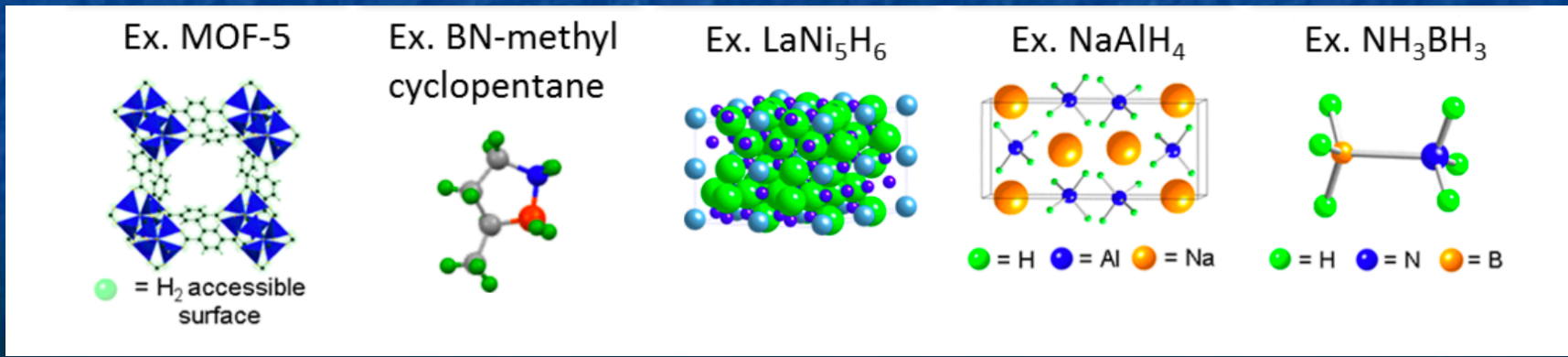

1) <https://www.energy.gov/eere/fuelcells/physical-hydrogen-storage>

2) <https://www.energy.gov/eere/fuelcells/hydrogen-storage>

# What sort of mass or volume energy densities are (or might be) achieved)?

From the second US DOE Office of Energy Efficiency & Renewable Energy webpage: 1

## Projected Performance and Cost of Compressed Automotive Hydrogen Storage Systems Compared to 2020 and Ultimate DOE Targets<sup>a</sup>

Storage System Targets	Gravimetric Density kWh/kg system (kg H <sub>2</sub> /kg system)	Volumetric Density kWh/L system (kg H <sub>2</sub> /L system)	Cost \$/kWh (\$/kg H <sub>2</sub> )
2020	1.5 (0.045)	1.0 (0.030)	\$10 (\$333)
Ultimate	2.2 (0.065)	1.7 (0.050)	\$8 (\$266)
Current Status (from Argonne National Laboratory)	Gravimetric Density kWh/kg system (kg H <sub>2</sub> /kg system)	Volumetric Density kWh/L system (kg H <sub>2</sub> /L system)	Cost <sup>b</sup> \$/kWh (\$/kg H <sub>2</sub> )
700 bar compressed (Type IV, single tank)	1.4 (0.042)	0.8 (0.024)	\$15 <sup>c</sup> (\$500)

<sup>a</sup> Assumes a storage capacity of 5.6 kg of usable hydrogen.  
<sup>b</sup> Cost projections are estimated at 500,000 units per year and are reported in 2007\$.  
<sup>c</sup> Cost projection from Strategic Analysis (November 2015).

Using results for COMPLETE STORAGE SYSTEMS (H<sub>2</sub>, tank, pump, material, . . .)

for both 2020 and projected "Ultimate" storage systems,

I can add to my table arrows for the energy density of STORED hydrogen:

## H<sub>2</sub> Storage System

## Energy / Mass

## Energy / Volume

## H<sub>2</sub> Storage System

**Gravimetric Density**  
kWh/kg system (kg  
H<sub>2</sub>/kg system)

1.5 (0.045) **2020**

2.2 (0.065) **Ultimate**

Substance	Specifics:	Energy / Mass			Energy / Volume		
		MJ / kg	kW-h / kg	Ratio to Gasoline	MJ / liter	kW-h / liter	Ratio to Gasoline
Hydrogen Gas (H <sub>2</sub> ) at 20°C	150 Atm. gas *	142	39.4	3.1	1.79	0.50	0.05219
	1 Atm. gas	142	39.4	3.1	0.0119	0.0033	0.00035
Methane Gas at 15°C	150 Atm. gas *	55.6	15.4	1.2	5.67	1.58	0.1658
	1 Atm. Gas	55.6	15.4	1.2	0.0378	0.011	0.0011
Natural Gas at 15°C	150 Atm. gas *	53.6	14.9	1.16	5.46	1.5	0.1596
	1 Atm. gas	53.6	14.9	1.16	0.0364	0.010	0.0011
Propane LPG	Liquid	49.6	13.8	1.1	25.3	7.03	0.74
Diesel Fuel	Liquid	45.6	12.7	1.0	38.6	10.7	1.13
Gasoline	Liquid	46.4	12.9	1.0	34.2	9.5	1
Jet Fuel (Kerosene)	Liquid	43	11.9	0.93	35	9.7	1.02
Fat	Animal or Vegetable	37	10.3	0.80	34	9.4	0.99
Coal	Anthracite or Bituminous	30	8.3	0.65	38	10.6	1.11
Carbohydrates	Including Sugars	17	4.7	0.37			
Ammonia	Liquid	16.9	4.7	0.36	11.5	3.2	0.336
Protein		16.8	4.7	0.36			
Wood		16.2	4.5	0.35	13	3.6	0.380
TNT		4.61	1.3	0.10	6.92	1.9	0.202
Gun Powder		3	0.8	0.065			
Lithium (Mn) Metal Battery		1.01	0.28	0.022	2.09	0.6	0.061
Lithium Ion Battery		0.72	0.20	0.016	3.6	1.00	0.105
Flywheel		0.50	0.14	0.011			
Alkaline Battery		0.59	0.16	0.013	1.43	0.40	0.042
Nickel Metal Hydride Battery		0.40	0.11	0.0086	1.55	0.43	0.045
Lead Acid Battery		0.14	0.039	0.0030	0.36	0.10	0.011
Super Capacitor		0.020	0.006	0.0004	0.050	0.014	0.0015
Capacitor		0.002	0.001	0.00004			

\* Effective Energy / Mass is as much as 100 times smaller for high-pressure gas in heavy tanks

Table source: [https://WeCanFigureThisOut.org/ENERGY/Energy\\_home.htm](https://WeCanFigureThisOut.org/ENERGY/Energy_home.htm)

**Volumetric Density**  
kWh/L system (kg  
H<sub>2</sub>/L system)

1.0 (0.030) **2020**

1.7 (0.050) **Ultimate**

"Ultimate" H<sub>2</sub> energy storage density is predicted to be 5-7X **LESS** than Gasoline

Further, that "ultimate" density is only about 10X **TODAY'S** Li Batteries

## *Superior stored energy density drives interest in **AMMONIA** fuel cell powered ships*

The difference comes from the sharply contrasting properties of  $H_2$  vs.  $NH_3$ :

**Hydrogen boils at minus 253.9 °C** - Hugely below room temperature!

Making its bulk liquefaction almost certainly impractical

Leaving extreme high pressures as the only proven way of concentrating it

=> **~700 atmosphere pressures mentioned** in my table & elsewhere

Which, in turn, demands the use of massive pressure tanks + pumping systems

**Ammonia boils at minus 33.3 °C** and thus:

At room temperature it liquifies at only ~ **9 atmospheres** of pressure <sup>1</sup>

Which requires only simple compressors & tanks, comparable to the air versions used in our homes by carpenters and DIY'ers

OR if tanks are cooled to only -33.3 °C, Ammonia pressure falls to 1 atmosphere

Requiring only lightly built and lightly cooled storage tanks

1) [https://www.engineeringtoolbox.com/ammonia-pressure-temperature-d\\_361.html](https://www.engineeringtoolbox.com/ammonia-pressure-temperature-d_361.html)

# What sort of Ammonia energy storage densities might be thereby achieved?

According to a UK Royal Society study, <sup>1</sup> using **already established** technologies,

**+25 °C** Ammonia storage systems should achieve energy densities of **~3 kW-h / liter**

**-35 °C** Ammonia storage systems should achieve energy densities of almost **4 kW-h / liter**

Substance	Specifics:	Energy / Mass			Energy / Volume		
		MJ / kg	kWh / kg	Ratio to Gasoline	MJ / liter	kWh / liter	Ratio to Gasoline
Hydrogen (H <sub>2</sub> ) at 20°C	150 Atm. gas *	142	39.4	3.0	1.79	0.495	0.052
	1 Atm. gas				0.0119	0.0033	0.00035
Methane at -162°C	Liquefied	55.5	15.4	1.2	22.2	6.16	0.65
	Diesel Fuel	48	13.3	1.03	35.8	9.94	1.04
Propane / Butane LPG	Liquid	46.4	12.9	1	26	7.2	0.76
Gasoline	Liquid	46.4	12.9	1	34.2	9.5	1
Jet Fuel (Kerosene)	Liquid	42.8	11.9	0.92	37.4	10.4	1.09
Fat	Animal or Vegetable	37	10.3	0.79	34	9.4	0.99
Coal	Anthracite or Bituminous	~ 30	~ 8	0.65	~ 38	~ 11	1.1
Natural Gas at 15°C (70-80% CH <sub>4</sub> )	150 Atm. gas *	26.9	7.45	0.58	5.19	1.43	0.15
	1 Atm. gas				0.0344	0.0001	0.0001
Protein		16.8	4.6	0.36			
Carbohydrates	Including Sugars	17	4.7	0.37			
Protein		16.8	4.6	0.36			
Wood		16.2	4.5	0.35	13	3.6	0.38
TNT		4.6		0.1			
Gun Powder		3	1.3	0.06			
Lithium Metal Battery		1.8	0.5	0.04	4.32	1.2	0.13
Lithium Ion Battery		0.36 - 0.875	0.1 - 0.24	0.007 - 0.02	0.9 - 2.63	0.25 - 0.0055	0.02 - 0.07
Flywheel		0.35 - 0.5	0.97 - 0.14	0.007 - 0.01			
Alkaline Battery		0.5	0.14	0.01	1.3	0.36	0.04
Nickel Metal Hydride Battery		0.288	0.08	0.006	0.504 - 1.08	0.14 - 0.3	0.01 - 0.03
Lead Acid Battery		0.17	0.047	0.03	0.56	0.15	0.016
Super Capacitor		0.01 - 0.036	0.003 - 0.01	0.0002 - 0.0008	0.05 - 0.06	0.014 - 0.016	0.001 - 0.002
Capacitor		0.00001 - 0.0002	0.000003 - 0.0005	0.0000002 - 0.0000004	0.00001 - 0.001	0.000003 - 0.0003	0.0000003 - 0.00003

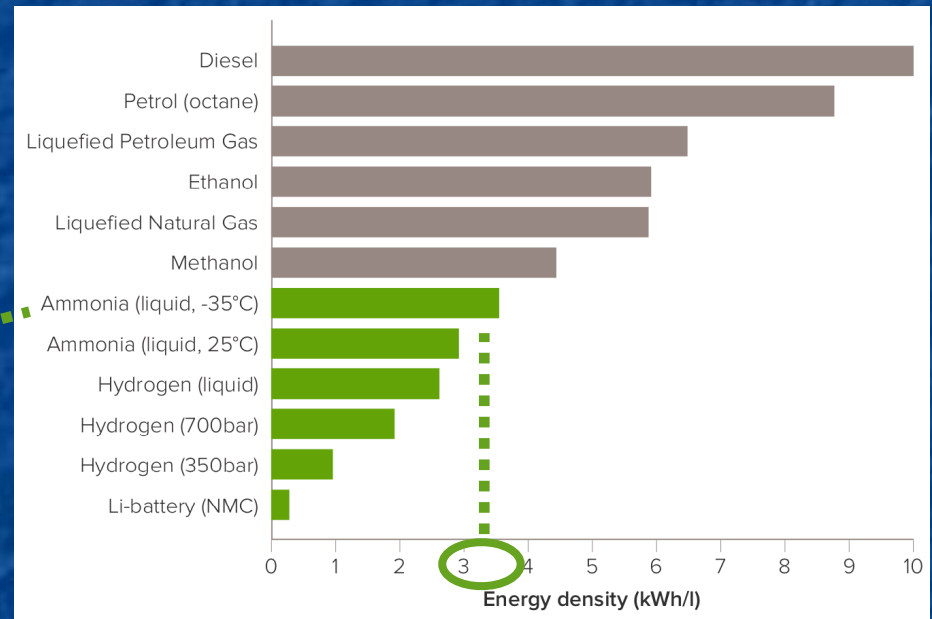

That compares with the earlier DOE Hydrogen energy storage system figures of 1 kW-h / liter in 2020, growing ultimately to 1.7 kW-h / liter

**Giving Ammonia storage systems a near term advantage of 3-4X**

<sup>1</sup> Figure at right from page 7 in: <https://royalsociety.org/topics-policy/projects/low-carbon-energy-programme/green-ammonia/>



But DOE's projected limits might be slanted toward "Physical" H<sub>2</sub> storage <sup>1</sup>

Because alternative "Material" based H<sub>2</sub> storage is still in only early research stages

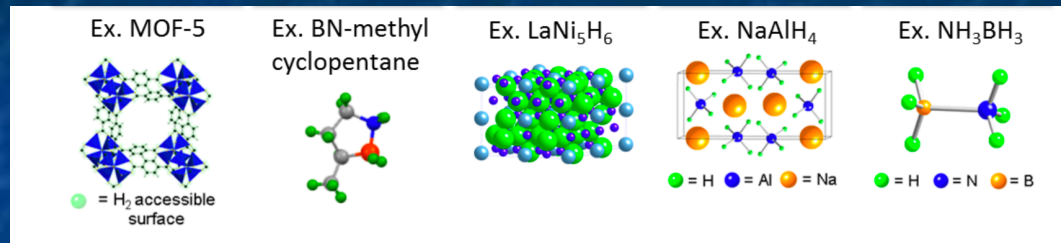

As an experienced nanoscientist, <sup>2, 3</sup> what might I expect from Material-based systems?

Tiny H<sub>2</sub> molecules could easily slither into gaps in the above crystalline structures,

and might continue to do so until their accumulation began to stretch those crystals

Say that things continued until H<sub>2</sub> molecules got within ~ 10 crystal atoms of each other

For crystal atom spacings of ~ 0.2 nm, H<sub>2</sub> molecule spacing would then be 2 nm

=> H<sub>2</sub> molecular concentration of  $1 / (2 \text{ nm})^3 = 1 / (2 \times 10^{-7} \text{ cm})^3 \sim 10^{20} \text{ H}_2 \text{ molecules} / \text{cm}^3$

700 ATM H<sub>2</sub> gas would instead contain: <sup>4, 5</sup>  $\sim 2 \times 10^{22} \text{ H}_2 \text{ molecules} / \text{cm}^3$

**Giving Material-based H<sub>2</sub> storage a limit ~ 200 times smaller than 700 ATM H<sub>2</sub>**

Corresponding to ~ 0.2 kW-h/ kg or 0.01 kW-h / l => Below DOE predicted maximums

<sup>1</sup> Their two webpages (cited earlier) provide essentially no details

<sup>2</sup> My patents: <https://wecanfigurethisout.org/ABOUT/Patents.htm> <sup>3</sup> My publications: <https://wecanfigurethisout.org/ABOUT/Publications.htm>

<sup>4</sup> Calculated from the Ideal Gas Law:  $n/V = P / kT$  <sup>5</sup> My calculation checked via: <https://www.gigacalculator.com/calculators/ideal-gas-law-calculator.php>

***Leaving H<sub>2</sub> Fuel Cells a single unambiguous / undisputed advantage:***

*Fuel Cells can be recharged much more quickly than Batteries*

**Which is countered by one repeatedly cited disadvantage:**

Fuel Cells have much lower Energy Return Efficiencies than Batteries

= Net Extractable Energy / Net Energy Required to Charge

As discussed much earlier, Batteries can return up to ~ **90%** of the energy put into them

But Fuel Cells return far less of that energy

From an impressively extensive Wikipedia table, for H<sub>2</sub> Fuel Cells: <sup>1</sup>

<b>H<sub>2</sub> Fuel Cell Type:</b>	<b>Alkaline</b>	<b>Proton Exchange Membrane</b>	<b>Solid Oxide</b>
<b>Return Efficiency:</b>	<b>62%</b>	<b>30-50%</b>	<b>55-60%</b>

*Looking for corroboration of such low numbers from other sources:*

1) [https://en.wikipedia.org/wiki/Fuel\\_cell](https://en.wikipedia.org/wiki/Fuel_cell)

# Somewhat higher for some Fuel Cell types - But still far inferior to batteries: 1

U.S. DEPARTMENT OF  
**ENERGY**

Energy Efficiency &  
Renewable Energy

**FUEL CELL TECHNOLOGIES OFFICE**

## Comparison of Fuel Cell Technologies

Fuel Cell Type	Common Electrolyte	Operating Temperature	Typical Stack Size	Electrical Efficiency (LHV)	Applications	Advantages	Challenges
<b>Polymer Electrolyte Membrane (PEM)</b>	Perfluorosulfonic acid	<120°C	<1 kW - 100 kW	60% direct H <sub>2</sub> <sup>i</sup> 40% reformed fuel <sup>ii</sup>	<ul style="list-style-type: none"> <li>Backup power</li> <li>Portable power</li> <li>Distributed generation</li> <li>Transportation</li> <li>Specialty vehicles</li> </ul>	<ul style="list-style-type: none"> <li>Solid electrolyte reduces corrosion &amp; electrolyte management problems</li> <li>Low temperature</li> <li>Quick start-up and load following</li> </ul>	<ul style="list-style-type: none"> <li>Expensive catalysts</li> <li>Sensitive to fuel impurities</li> </ul>
<b>Alkaline (AFC)</b>	Aqueous potassium hydroxide soaked in a porous matrix, or alkaline polymer membrane	<100°C	1 - 100 kW	60% <sup>iii</sup>	<ul style="list-style-type: none"> <li>Military</li> <li>Space</li> <li>Backup power</li> <li>Transportation</li> </ul>	<ul style="list-style-type: none"> <li>Wider range of stable materials allows lower cost components</li> <li>Low temperature</li> <li>Quick start-up</li> </ul>	<ul style="list-style-type: none"> <li>Sensitive to CO<sub>2</sub> in fuel and air</li> <li>Electrolyte management (aqueous)</li> <li>Electrolyte conductivity (polymer)</li> </ul>
<b>Phosphoric Acid (PAFC)</b>	Phosphoric acid soaked in a porous matrix or imbibed in a polymer membrane	150 - 200°C	5 - 400 kW, 100 kW module (liquid PAFC); <10 kW (polymer membrane)	40% <sup>iv</sup>	<ul style="list-style-type: none"> <li>Distributed generation</li> </ul>	<ul style="list-style-type: none"> <li>Suitable for CHP</li> <li>Increased tolerance to fuel impurities</li> </ul>	<ul style="list-style-type: none"> <li>Expensive catalysts</li> <li>Long start-up time</li> <li>Sulfur sensitivity</li> </ul>
<b>Molten Carbonate (MCFC)</b>	Molten lithium, sodium, and/or potassium carbonates, soaked in a porous matrix	600 - 700°C	300 kW - 3 MW, 300 kW module	50% <sup>v</sup>	<ul style="list-style-type: none"> <li>Electric utility</li> <li>Distributed generation</li> </ul>	<ul style="list-style-type: none"> <li>High efficiency</li> <li>Fuel flexibility</li> <li>Suitable for CHP</li> <li>Hybrid/gas turbine cycle</li> </ul>	<ul style="list-style-type: none"> <li>High temperature corrosion and breakdown of cell components</li> <li>Long start-up time</li> <li>Low power density</li> </ul>
<b>Solid Oxide (SOFC)</b>	Yttria stabilized zirconia	500 - 1000°C	1 kW - 2 MW	60% <sup>vi</sup>	<ul style="list-style-type: none"> <li>Auxiliary power</li> <li>Electric utility</li> <li>Distributed generation</li> </ul>	<ul style="list-style-type: none"> <li>High efficiency</li> <li>Fuel flexibility</li> <li>Solid electrolyte</li> <li>Suitable for CHP</li> <li>Hybrid/gas turbine cycle</li> </ul>	<ul style="list-style-type: none"> <li>High temperature corrosion and breakdown of cell components</li> <li>Long start-up time</li> <li>Limited number of shutdowns</li> </ul>

<sup>i</sup> NREL Composite Data Product 8, "Fuel Cell System Efficiency," [http://www.nrel.gov/hydrogen/docs/cdp/cdp\\_8.jpg](http://www.nrel.gov/hydrogen/docs/cdp/cdp_8.jpg)

<sup>ii</sup> Panasonic Headquarters News Release, "Launch of New 'Ene-Farm' Home Fuel Cell Product More Affordable and Easier to Install," <http://panasonic.co.jp/corp/news/official.data/data.dir/2013/01/en130117-5/en130117-5.html>

<sup>iii</sup> G. Mulder et al., "Market-ready stationary 6 kW generator with alkaline fuel cells," ECS Transactions 12 (2008) 743-758

<sup>iv</sup> Doosan PureCell Model 400 Datasheet, [http://www.doosanfuelcell.com/attach\\_files/link/PureCell%20Model%20400%20Datasheet.pdf](http://www.doosanfuelcell.com/attach_files/link/PureCell%20Model%20400%20Datasheet.pdf)

<sup>v</sup> FuelCell Energy DFC300 Product Specifications, <http://www.fuelcellenergy.com/assets/DFC300-product-specifications1.pdf>

<sup>vi</sup> Ceramic Fuel Cells Gennex Product Specifications, <http://www.bloomenergy.com/fuel-cell/es5-data-sheet/>

## For More Information

More information on the Fuel Cell Technologies Office is available at <http://www.hydrogenandfuelcells.energy.gov>.

U.S. DEPARTMENT OF  
**ENERGY**

Energy Efficiency &  
Renewable Energy

For more information, visit:  
[hydrogenandfuelcells.energy.gov](http://hydrogenandfuelcells.energy.gov)

April 2016

Printed with a renewable-source ink on paper containing at least 50% wastepaper, including 10% post consumer waste.

## Or for Fuel Cells & Batteries designed for Grid Energy Load Leveling:

From the U.S. National Renewable Energy Lab: <sup>1</sup>

FC = Hydrogen Fuel Cell  
NaS = Molten Sodium Battery

VR = Vanadium Redox Flow Battery  
CAES = Compressed Air Energy Storage

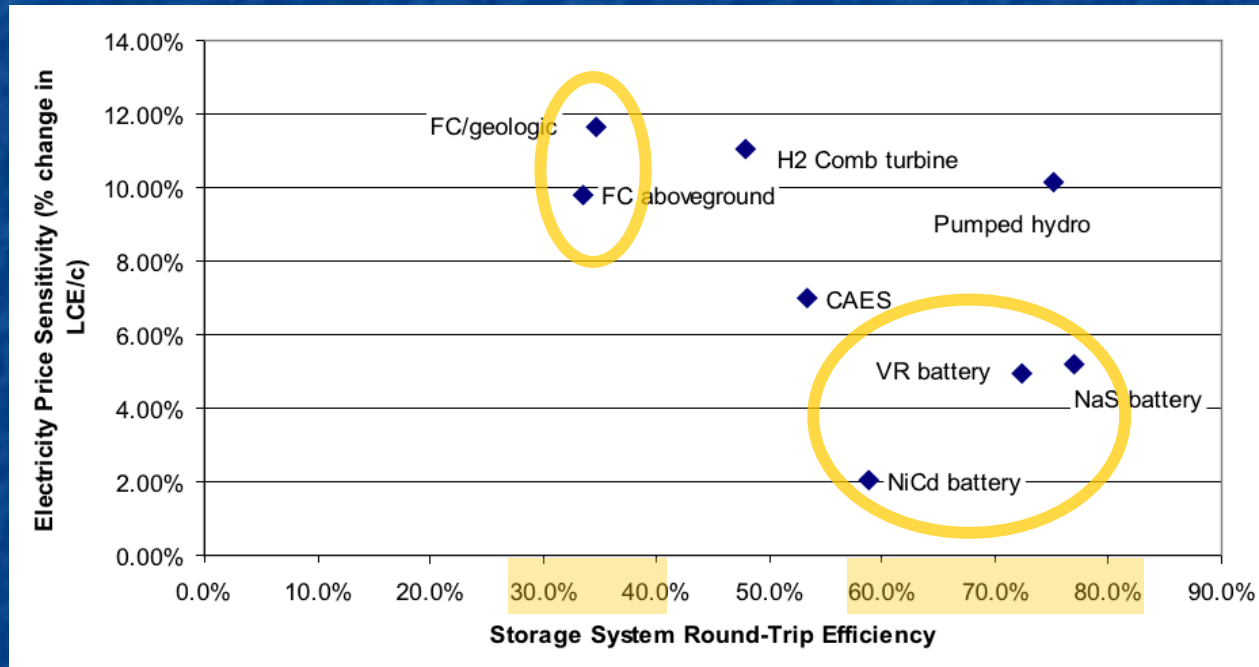

**Fuel Cell vs. Battery Bottom Line (at least for today)?**

**The energy return of Fuel Cells is 30-50% poorer than that of Batteries**

1) Yellow emphasis added to: <http://www.nrel.gov/docs/fy10osti/47547.pdf>

# *Credits / Acknowledgements*

Some materials used in this class were developed under a National Science Foundation "Research Initiation Grant in Engineering Education" (RIGEE).

Other materials, including the "Virtual Lab" science education website, were developed under even earlier NSF "Course, Curriculum and Laboratory Improvement" (CCLI) and "Nanoscience Undergraduate Education" (NUE) awards.

This set of notes was authored by John C. Bean who also created all figures not explicitly credited above.

**Copyright John C. Bean**

(However, permission is granted for use by individual instructors in non-profit academic institutions)